

0805 ASM

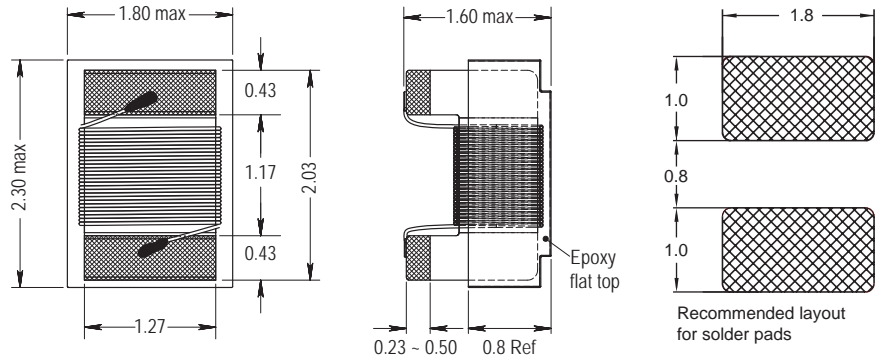

Non-magnetic
Engineer's Kit: EK-0805ASM-X

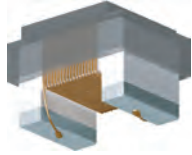

Chip Inductors for RF / Medical Applications (Wire wound - open)

Chip Inductors for RF / Medical Applications (Wire wound - open)

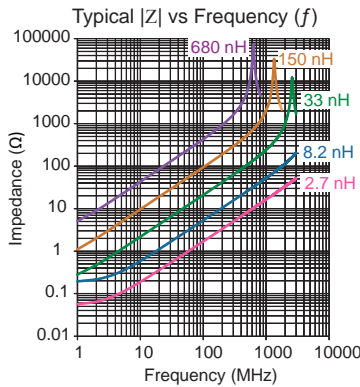
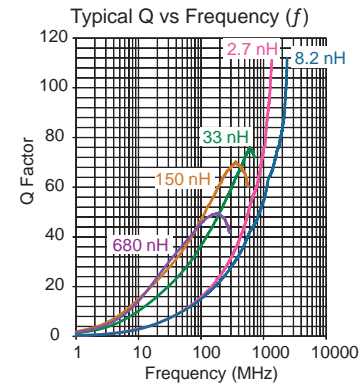
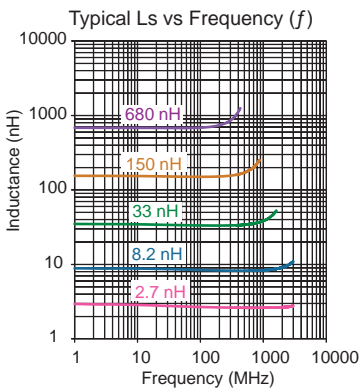

Single layer (typ)

Part No	Inductance	f _L	Tol	Q	f _α	SRF	DCR	Rated DC
	L (nH)	(MHz)	± (%)	min	(MHz)	(MHz)	max (Ω)	Current (mA)
0805ASM-2N7K-YY	2.7	250	10	80	1500	6000 min	0.08	600
0805ASM-3N3K-YY	3.3	250	10	50	1500	6000 min	0.08	600
0805ASM-5N6K-YY	5.6	250	10	53	1000	5500 min	0.11	600
0805ASM-5N8K-YY	5.8	250	10	50	1000	5500 min	0.11	600
0805ASM-6N8K-YY	6.8	250	10	50	1000	5500 min	0.11	600
0805ASM-8N0K-YY	8.0	250	10	51	1000	4700 min	0.12	600
0805ASM-8N2K-YY	8.2	250	10	50	1000	4700 min	0.12	600
0805ASM-010J-YY	10	250	5	43	1000	4300 min	0.13	600
0805ASM-012J-YY	12	250	5	50	500	4000 min	0.15	600
0805ASM-015J-YY	15	250	5	50	500	3400 min	0.17	600
0805ASM-018J-YY	18	250	5	53	500	3300 min	0.20	500
0805ASM-022J-YY	22	250	5	57	500	2600 min	0.22	500
0805ASM-027J-YY	27	250	5	55	500	2500 min	0.25	500
0805ASM-033J-YY	33	250	5	60	500	2050 min	0.27	500
0805ASM-036J-YY	36	250	5	60	500	2050 min	0.27	600
0805ASM-039J-YY	39	250	5	60	500	2000 min	0.29	500
0805ASM-047J-YY	47	200	5	65	500	1650 min	0.31	500
0805ASM-056J-YY	56	200	5	64	500	1550 min	0.34	500
0805ASM-068J-YY	68	200	5	65	500	1450 min	0.38	400
0805ASM-075J-YY	75	200	5	55	500	1300 min	0.42	400
0805ASM-082J-YY	82	150	5	67	500	1300 min	0.42	400
0805ASM-R10J-YY	100	150	5	65	500	1200 min	0.46	400
0805ASM-R12J-YY	120	150	5	52	250	1100 min	0.51	400
0805ASM-R13J-YY	130	100	5	53	250	920 min	0.56	400
0805ASM-R15J-YY	150	100	5	60	250	920 min	0.56	400
0805ASM-R18J-YY	180	100	5	50	250	870 min	0.64	400
0805ASM-R20J-YY	200	100	5	54	250	850 min	0.70	400
0805ASM-R22J-YY	220	100	5	59	250	850 min	0.70	400
0805ASM-R24J-YY	240	100	5	52	250	850 min	0.80	400
0805ASM-R25J-YY	250	100	5	52	250	850 min	0.80	400
0805ASM-R27J-YY	270	100	5	40	100	820 min	1.50	280
0805ASM-R29J-YY	290	100	5	40	100	795 min	1.80	260
0805ASM-R30J-YY	300	100	5	40	100	795 min	1.80	260
0805ASM-R33J-YY	330	100	5	40	100	790 min	1.80	260
0805ASM-R39J-YY	390	100	5	42	100	750 min	2.00	200
0805ASM-R47J-YY	470	100	5	40	100	720 min	2.50	170
0805ASM-R56J-YY	560	100	5	40	100	650 min	3.50	170
0805ASM-R68J-YY	680	50	5	37	75	450 min	3.50	170
0805ASM-R75K-YY	750	25	10	23	50	215 typ	2.35	180
0805ASM-R82K-YY	820	25	10	23	50	215 typ	2.35	180
0805ASM-1R0K-YY	1000	25	10	23	50	215 typ	2.35	180
0805ASM-2R2K-YY	2200	7.9	10	15	7.9	80 typ	3.80	150
0805ASM-2R7K-YY	2700	7.9	10	15	7.9	80 typ	4.80	120

Core Material: Ceramic

Revision date: 12 Nov 2025

SPQ: Taped / Reel 1000 [-08]
2500 [-01]
7500 [-04]

Remarks: - Unlisted inductance values available upon request.
- 2% and 5% tolerance available upon request.

• All dimensions in mm