

## FEATURES

- Low power CMOS process
- Wide operation voltage range: 1.65~5.5V
- Ultra-low power consumption, <math><5\mu\text{A}</math>@1.8V
- Good RF noise immunity
- -40°C to +85°C operation
- RoHS compliant

## APPLICATIONS

- TWS headset
- Smart meter
- Cover switch
- Domestic appliances
- Laptop
- Industry

## DESCRIPTION

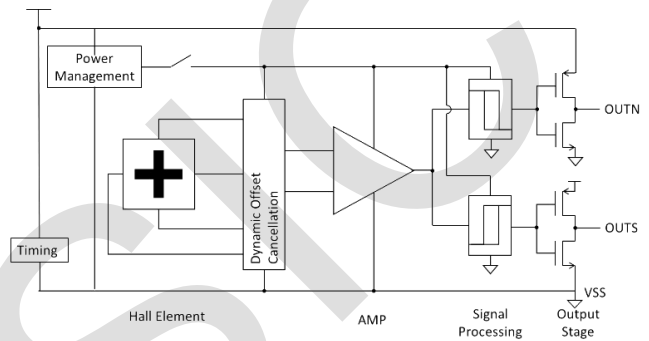

Figure 1: Signal Path

## Devices List

Devices	Package	Polarity	Output	ESD-HBM	Quantity / Reel
MHA182AS-S	SOT553	Single output S unipolar	push pull	±3.5KV	3000
MHA183AS	SOT23-3L	Single output Omnipolar	push pull	±4.5KV	3000

## SPECIFICATIONS (Measurements @ 25 °C, unless otherwise noted; V<sub>DD</sub>=1.8V unless otherwise specified)

Parameter	Conditions	Min	Typ	Max	Units
Supply Voltage (V <sub>DD</sub> )		1.65	1.8	5.5	V
Supply Current			2.5	5.0	μA
	-40~85 °C		2.5	10.0	μA
Power Down Current			1.0		nA
Operating Temperature		-40		85	°C
Storage Temperature		-55		125	°C
Awake Tim (T <sub>awake</sub> )			50	100	μs
Period (T <sub>period</sub> )			50	100	ms
Duty Cycle			0.05		%
Output High (V <sub>OH</sub> )	I <sub>OUT</sub> =+0.5mA	V <sub>DD</sub> -0.3	V <sub>DD</sub> -0.1	V <sub>DD</sub> +0.1	V
Output Low (V <sub>OL</sub> )	I <sub>OUT</sub> =-0.5mA	-0.3	0.1	0.3	V
Output Current		-0.5		0.5	mA
Sampling Frequency			20		Hz
Magnetic Opening Point (B <sub>OP</sub> )		27	37	47	Gauss
Magnetic Releasing Point (B <sub>RP</sub> )		17	27	37	Gauss
Hysteresis Window (B <sub>HYS</sub> )		3	10	17	Gauss

### SOT23 PIN DESCRIPTION

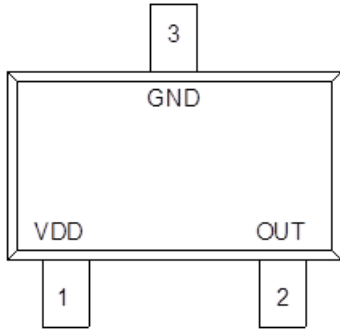

Pin NO.	Pin name	Description
1	VDD	Power supply
2	OUT	S or N pole detection output
3	GND	Ground

### SOT553 PIN DESCRIPTION

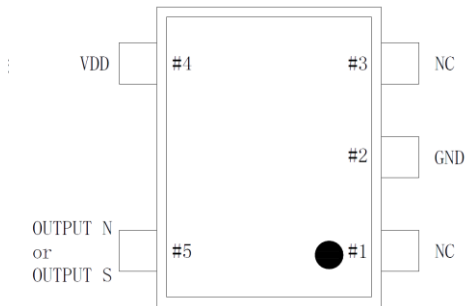

Pin NO.	Pin name	Description
1	NC	
2	GND	Ground
3	NC	
4	VDD	Power supply
5	OUT	S or N pole detection output

## THEORY OF OPERATION

This Hall switch is fully integrated CMOS IC. It output high-low signal following magnetic field changing. Normally it works with a magnet and detect the magnet close and away.

### The Hall Effect

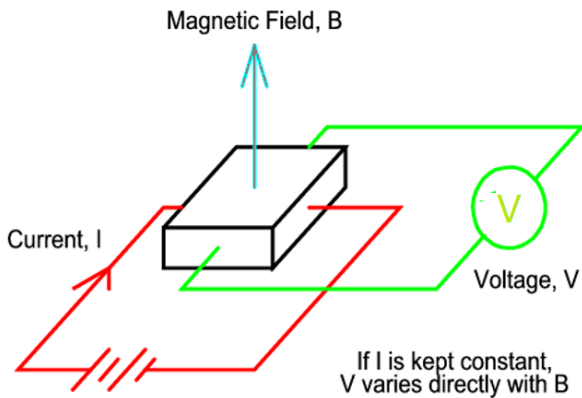

Figure 5: Hall Effect

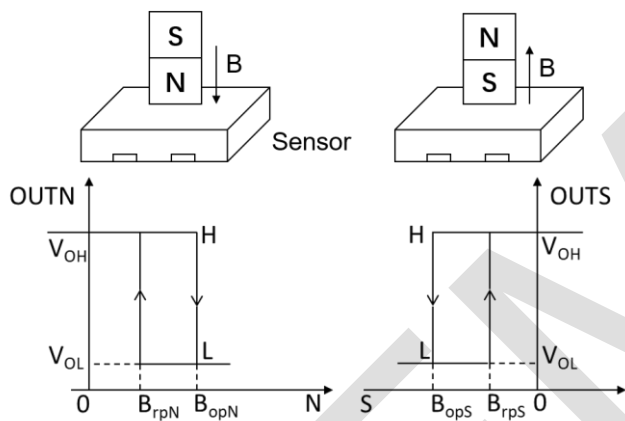

Figure 6: Output signals of OUTN and OUTS pins

MEMSIC

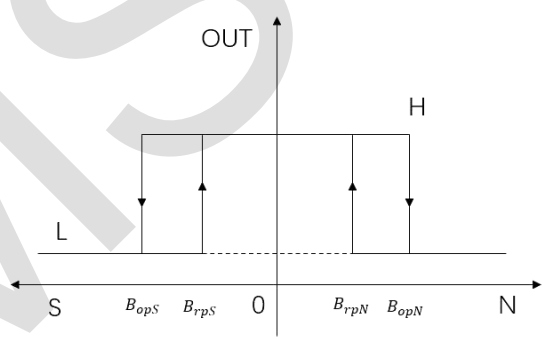

Figure 7: Output signals Omnipolar OUT pins

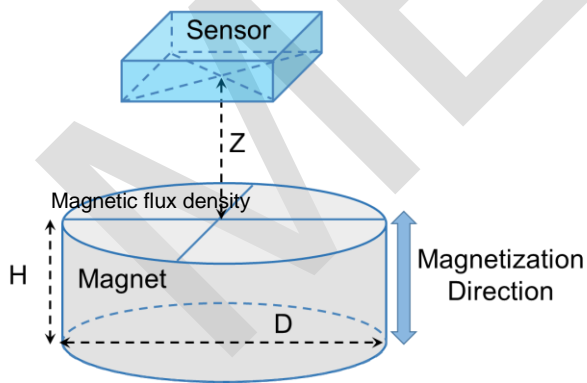

Figure 8: Sensor and magnet

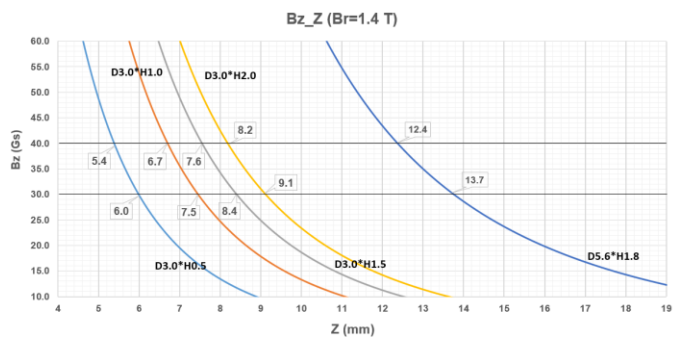

Figure 9: Field by magnet (different size and distance)

## SOLDER REFLOW PROFILE

1. Reflow is limited by 2 times. Second reflow should be applied after device has cooled down to room temperature (25°C).
2. Recommended reflow profile for Pb free process is shown in Figure 3. The time duration of peak temperature (260°C) should be limited to 10 seconds.
3. Type 4 solder paste is recommended for a better SMT quality.

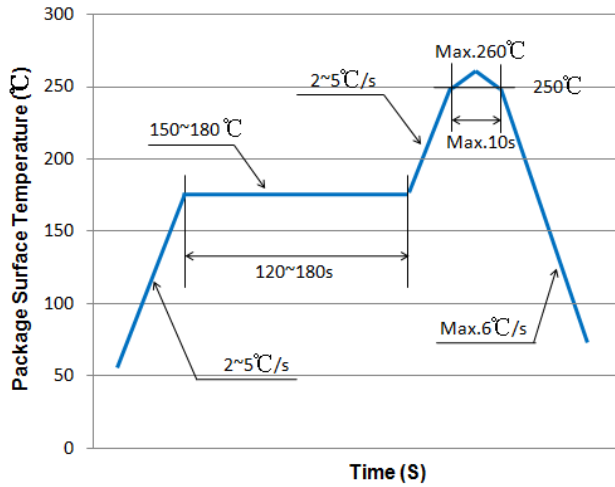

Figure 10: Recommended solder reflow profile

## MANUAL SOLDERING

1. Soldering/repairing MHA18x manually via solder iron or heater gun is not recommended.
2. Avoid bending or torquing the PCB after the sensor is assembled.



## SOT553 PACKAGE OUTLINE DIMENSION

Unit: mm

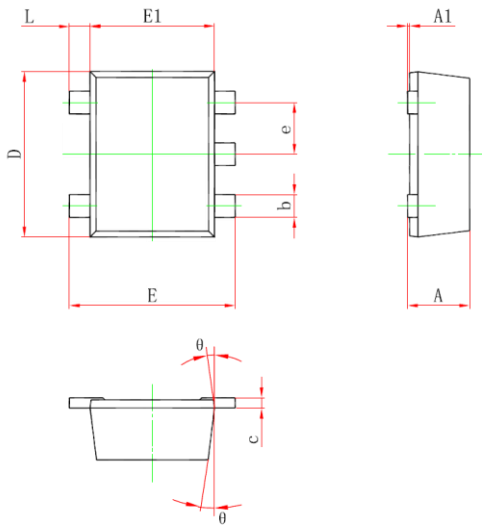

Symbol	Dimensions In Millimeters		Dimensions In Inches	
	Min.	Max.	Min.	Max.
A	0.525	0.600	0.021	0.024
A1	0.000	0.050	0.000	0.002
e	0.450	0.550	0.018	0.022
c	0.090	0.160	0.004	0.006
D	1.500	1.700	0.059	0.067
b	0.170	0.270	0.007	0.011
E1	1.100	1.300	0.043	0.051
E	1.500	1.700	0.059	0.067
L	0.100	0.300	0.004	0.012
$\theta$	7 °REF.		7 °REF.	

Figure 15: Mechanical package outline dimensions

Notes:

- c) Sensitive area located at the center of package within 0.3mm diameter circle.
- d) Unless otherwise specified, Tolerances is  $\pm 0.05\text{mm}$ .

## SOT553 TAPE AND REEL

Products are put into carrier tape according to package type. The quantity for each full reel is 3000pcs per reel with 7" lock reel. Please refer to below Figure

Details for tape and reel packing as below:

- a) Tape and reel carriers are in accordance with ANSI/EIA-481
- b) Tape and reels are NOT designed to be baked at high temperatures
- c) Each tape and reel is typically dry packed in a moisture barrier bag (MSL1).

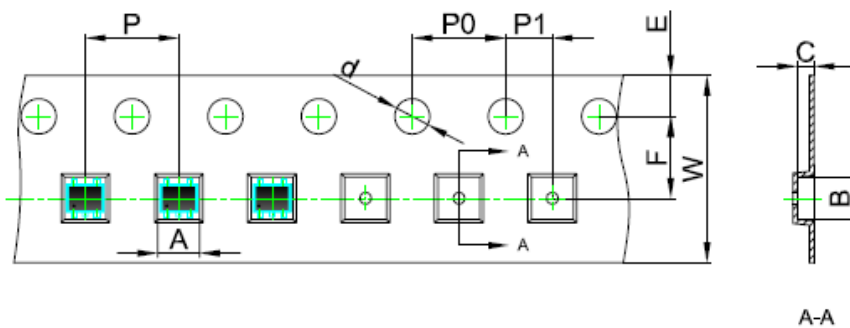

Dimensions are In millimeter										
Pkg type	A	B	C	d	E	F	P0	P	P1	W
SOT-553	1.78	1.78	0.69	$\text{Ø}1.50$	1.75	3.50	4.00	4.00	2.00	8.00
(Tolerance)	$\pm 0.1$	$\pm 0.1$	$\pm 0.1$	$\pm 0.1$	$\pm 0.1$	$\pm 0.1$	$\pm 0.1$	$\pm 0.1$	$\pm 0.1$	$\pm 0.1$

Figure 16: Carrier tape dimension and device orientation

# Mouser Electronics

Authorized Distributor

Click to View Pricing, Inventory, Delivery & Lifecycle Information:

[MEMSIC:](#)

[MHA182AS-S](#) [MHA183AS](#)