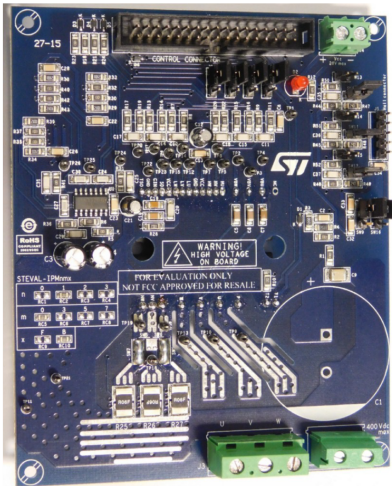


2500 W motor control power board based on STGIB30M60TS-L SLLIMM™ 2nd series IPM



Features

- Input voltage: 125 - 400 VDC
- Nominal power: up to 2500 W
 - Allowable maximum power is related to the application conditions and cooling system
- Nominal current: up to 18 A_{rms}
- Input auxiliary voltage: up to 20 V DC
- Single- or three-shunt resistors for current sensing (with sensing network)
- Two options for current sensing: dedicated op-amps or through MCU
- Overcurrent hardware protection
- IPM temperature monitoring and protection
- Hall sensor or encoder input
- IGBT intelligent power module:
 - SLLIMM™ 2nd series IPM (STGIB30M60TS-L - DBC package)
- Motor control connector (32-pin) to interface with ST MCU boards
- Universal conception for further evaluation with breadboard and testing pins
- Very compact size
- WEEE compliant
- RoHS compliant

Product summary	
2500 W motor control power board based on STGIB30M60TS-L SLLIMM™ 2nd series IPM	STEVAL-IPM30B
SLLIMM 2nd series IPM, 3-phase inverter, 35 A, 600 V short-circuit rugged IGBT	STGIB30M60TS-L STGIB30M60TS-E
Featured technologies	STPOWER SLLIMM
Development environments	STM32 MCSDK STSW-POWERSTUDIO
Applications	PMSM / BLDC Motor 3-phase Induction Motor (ACIM)

Description

The **STEVAL-IPM30B** is a compact motor drive power board equipped with the SLLIMM (small low-loss intelligent molded module) 2nd series module **STGIB30M60TS-L**. It provides an affordable, easy-to-use solution for driving high power motors for a wide range of applications such as white goods, air conditioners, compressors, power fans, high-end power tools, and generally 3-phase inverters for motor drives.

The IPM itself consists of short-circuit rugged IGBTs and a wide range of features including undervoltage lockout, smart shutdown, temperature sensing and NTC inside, and overcurrent protection.

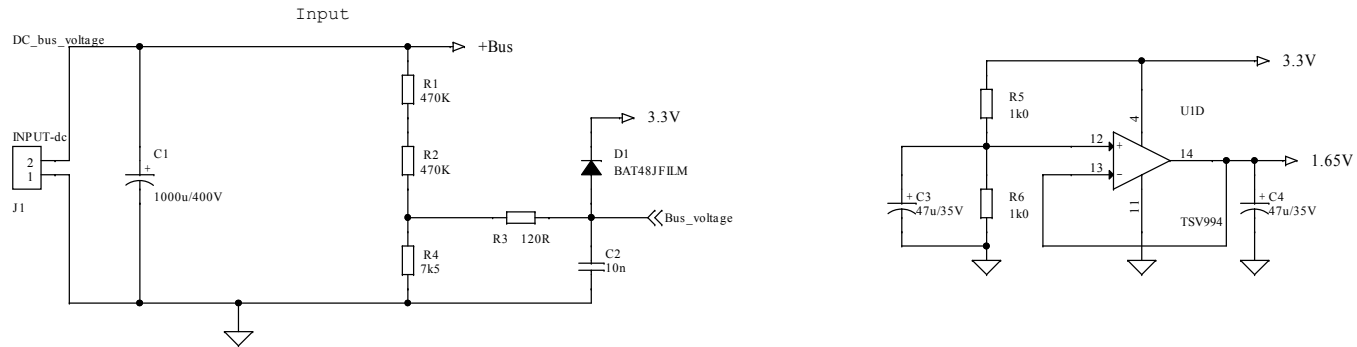
The main characteristics of this evaluation board are its small size, minimal BOM and high efficiency. It consists of an interface circuit (BUS and V_{CC} connectors), bootstrap capacitors, snubber capacitor, hardware short-circuit protection, fault event signal and temperature monitoring. It is designed to work in single or three-shunt configuration and with two current sensing options: three dedicated op-amps on the evaluation board, or op-amps available on a connected microcontroller. A Hall/Encoder section completes the circuit.

The system is designed to achieve accurate and fast conditioning of current feedback to satisfy the typical requirements for field-oriented control (FOC).

The **STEVAL-IPM30B** is compatible with ST control boards based on STM32 microcontrollers, providing a complete platform for motor control.

1 Schematic diagrams

Figure 1. STEVAL-IPM30B board schematic (1 of 5)



STEVAL-IPM1nmx decoder

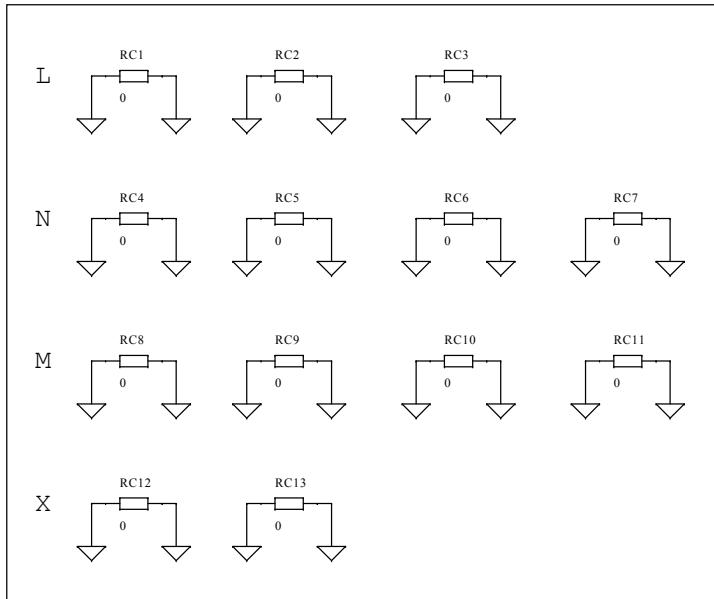


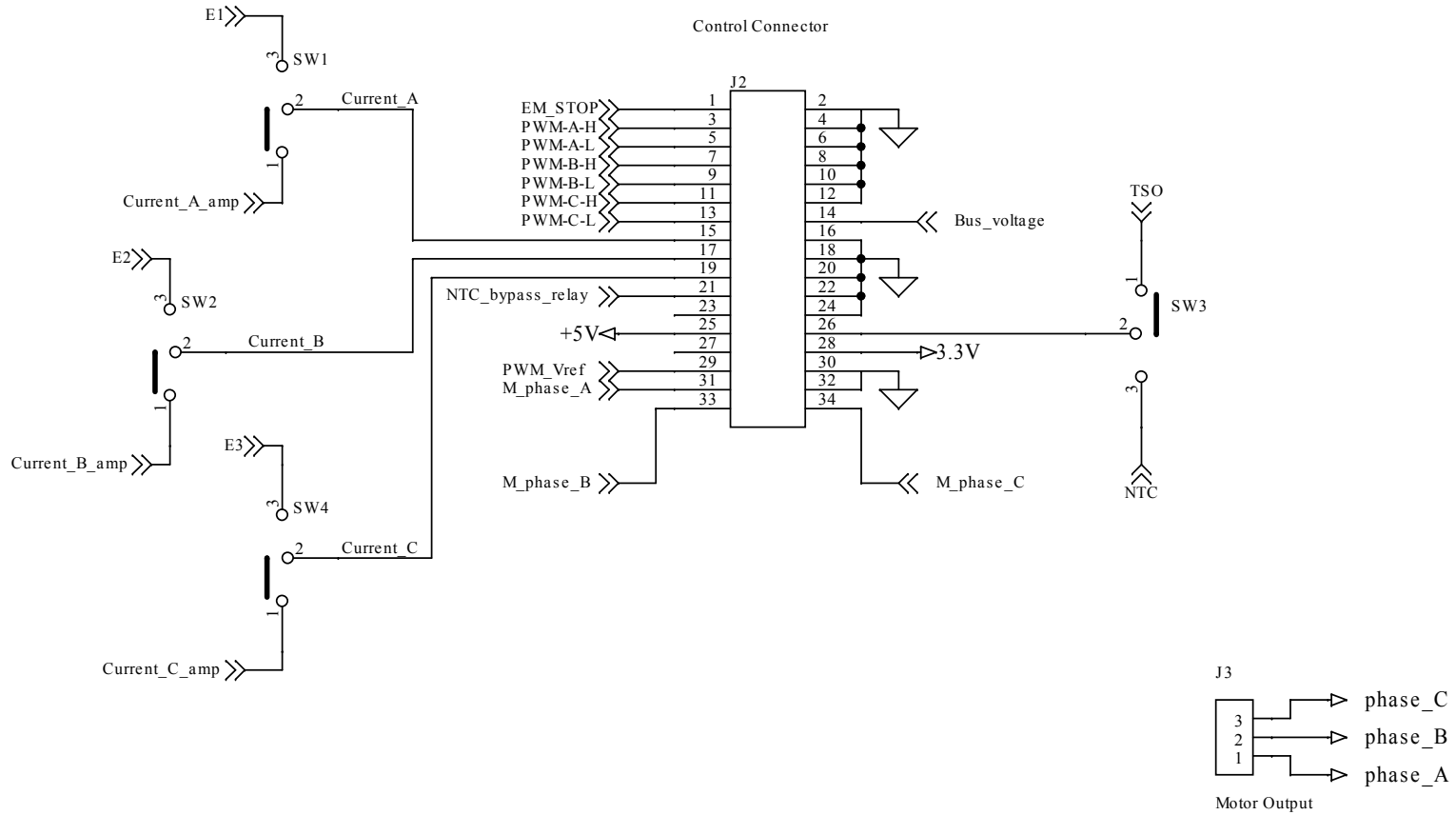
Figure 2. STEVAL-IPM30B board schematic (2 of 5)


Figure 3. STEVAL-IPM30B board schematic (3 of 5)

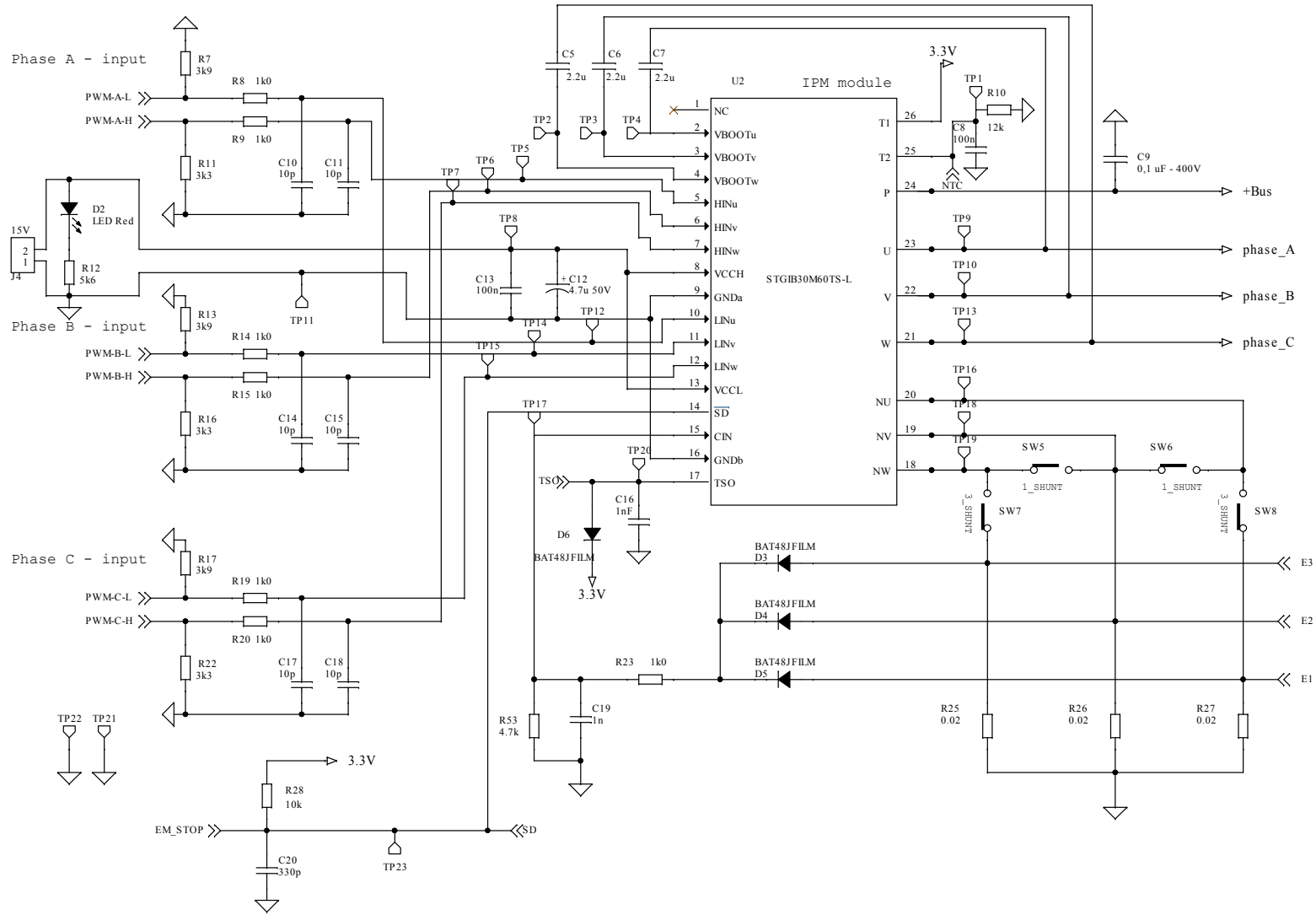


Figure 4. STEVAL-IPM30B board schematic (4 of 5)

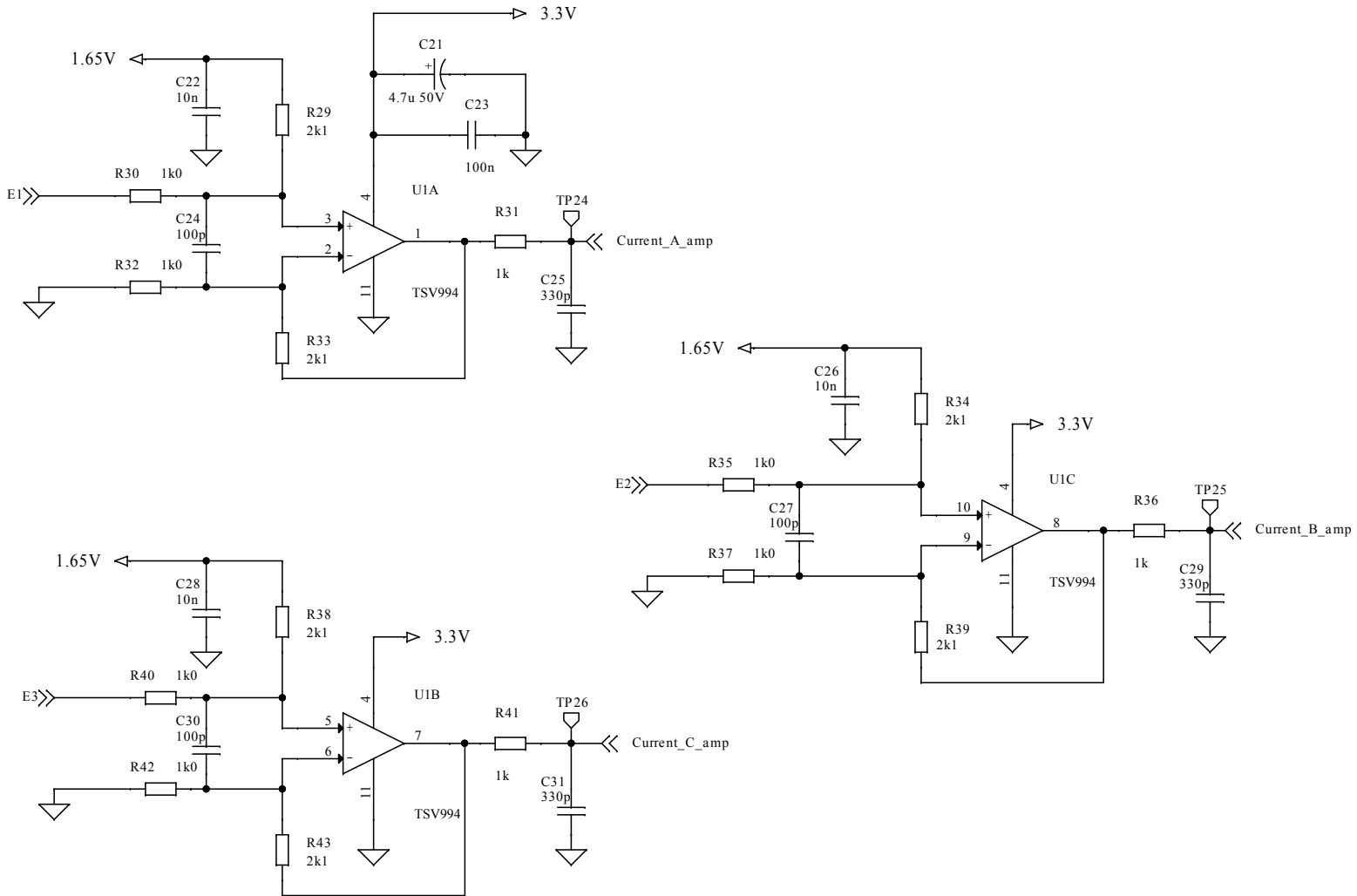
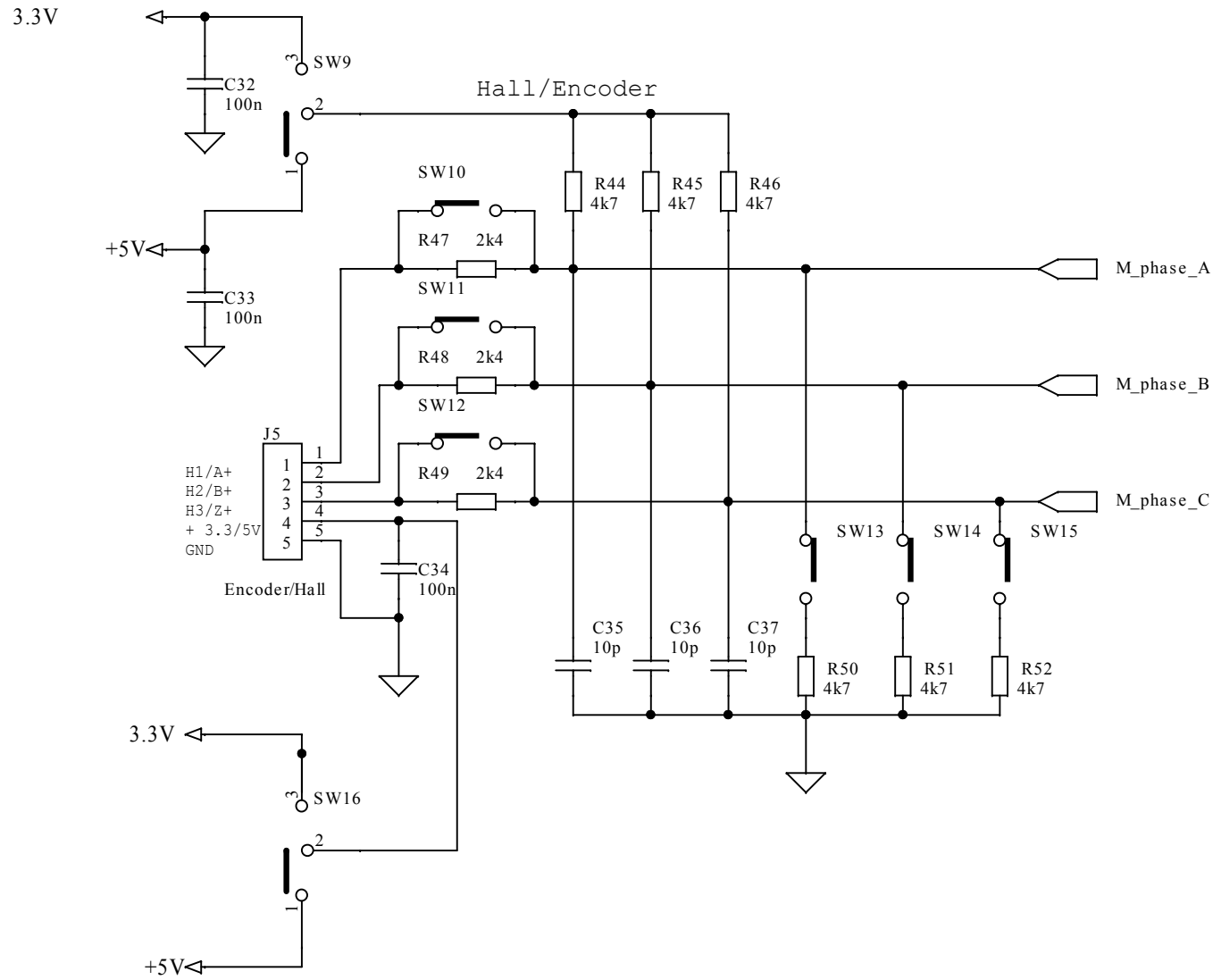


Figure 5. STEVAL-IPM30B board schematic (5 of 5)



Revision history

Table 1. Document revision history

Date	Version	Changes
11-Mar-2020	1	Initial release.
20-Apr-2020	2	Updated Section 1 Schematic diagrams

IMPORTANT NOTICE – PLEASE READ CAREFULLY

STMicroelectronics NV and its subsidiaries (“ST”) reserve the right to make changes, corrections, enhancements, modifications, and improvements to ST products and/or to this document at any time without notice. Purchasers should obtain the latest relevant information on ST products before placing orders. ST products are sold pursuant to ST’s terms and conditions of sale in place at the time of order acknowledgement.

Purchasers are solely responsible for the choice, selection, and use of ST products and ST assumes no liability for application assistance or the design of Purchasers’ products.

No license, express or implied, to any intellectual property right is granted by ST herein.

Resale of ST products with provisions different from the information set forth herein shall void any warranty granted by ST for such product.

ST and the ST logo are trademarks of ST. For additional information about ST trademarks, please refer to www.st.com/trademarks. All other product or service names are the property of their respective owners.

Information in this document supersedes and replaces information previously supplied in any prior versions of this document.

© 2020 STMicroelectronics – All rights reserved

Mouser Electronics

Authorized Distributor

Click to View Pricing, Inventory, Delivery & Lifecycle Information:

[STMicroelectronics:](#)

[STEVAL-IPM30B](#)