

TLE4241SYS_SHIELD

User guide

LITIX™ Linear
Z8F80503016

About this document

Scope and purpose

The TLE4241GM is an AEC qualified adjustable current LITIX™ Linear device, especially designed to drive LEDs. It embeds:

- Built-in diagnosis and protection features
- Adjustable constant output current up to 70 mA
- Wide input voltage range
- Voltage loop availability to implement constant output voltage power supply

The device also incorporates a PWM input that offers the possibility to adjust the LED brightness by pulse width modulation.

The TLE4241SYS_SHIELD can be used for:

- Standalone evaluation board for TLE4241GM device
- Shield for Arduino

The board is especially suited to quickly setup demos in the context of blind spot indication as it features input for ultrasound sensor, has an integrated buzzer and features 3 LEDs. Such designs are typically found in rear radar applications or are directly integrated into mirrors.

Intended audience

The scope of this user guide is to provide instructions on the use of TLE4241SYS_SHIELD.

This user guide describes the TLE4241SYS_SHIELD with PCB version P02. Additionally, schematic version S02 is described.

Evaluation board

This board is to be used during the design-in process for evaluation and proof of concepts for new projects adopting the TLE4241GM.

Note: PCB and auxiliary circuits are NOT optimized for final customer design.

Important notice

“Evaluation Boards and Reference Boards” shall mean products embedded on a printed circuit board (PCB) for demonstration and/or evaluation purposes, which include, without limitation, demonstration, reference and evaluation boards, kits and design (collectively referred to as “Reference Board”).

Environmental conditions have been considered in the design of the Evaluation Boards and Reference Boards provided by Infineon Technologies. The design of the Evaluation Boards and Reference Boards has been tested by Infineon Technologies only as described in this document. The design is not qualified in terms of safety requirements, manufacturing and operation over the entire operating temperature range or lifetime.

The Evaluation Boards and Reference Boards provided by Infineon Technologies are subject to functional testing only under typical load conditions. Evaluation Boards and Reference Boards are not subject to the same procedures as regular products regarding returned material analysis (RMA), process change notification (PCN) and product discontinuation (PD).

Evaluation Boards and Reference Boards are not commercialized products, and are solely intended for evaluation and testing purposes. In particular, they shall not be used for reliability testing or production. The Evaluation Boards and Reference Boards may therefore not comply with CE or similar standards (including but not limited to the EMC Directive 2004/EC/108 and the EMC Act) and may not fulfill other requirements of the country in which they are operated by the customer. The customer shall ensure that all Evaluation Boards and Reference Boards will be handled in a way which is compliant with the relevant requirements and standards of the country in which they are operated.

The Evaluation Boards and Reference Boards as well as the information provided in this document are addressed only to qualified and skilled technical staff, for laboratory usage, and shall be used and managed according to the terms and conditions set forth in this document and in other related documentation supplied with the respective Evaluation Board or Reference Board.

It is the responsibility of the customer’s technical departments to evaluate the suitability of the Evaluation Boards and Reference Boards for the intended application, and to evaluate the completeness and correctness of the information provided in this document with respect to such application.

The customer is obliged to ensure that the use of the Evaluation Boards and Reference Boards does not cause any harm to persons or third party property.

The Evaluation Boards and Reference Boards and any information in this document is provided "as is" and Infineon Technologies disclaims any warranties, express or implied, including but not limited to warranties of non-infringement of third party rights and implied warranties of fitness for any purpose, or for merchantability.

Infineon Technologies shall not be responsible for any damages resulting from the use of the Evaluation Boards and Reference Boards and/or from any information provided in this document. The customer is obliged to defend, indemnify and hold Infineon Technologies harmless from and against any claims or damages arising out of or resulting from any use thereof.

Infineon Technologies reserves the right to modify this document and/or any information provided herein at any time without further notice.

Safety precautions

Safety precautions

Safety precautions

Note: Please note the following warnings regarding the hazards associated with development systems.

Table 1 Safety precautions





	<p>Warning: The evaluation or reference board contains DC bus capacitors which take time to discharge after removal of the main supply. Before working on the drive system, wait five minutes for capacitors to discharge to safe voltage levels. Failure to do so may result in personal injury or death. Darkened display LEDs are not an indication that capacitors have discharged to safe voltage levels.</p>
	<p>Caution: Only personnel familiar with the drive, power electronics and associated machinery should plan, install, commission and subsequently service the system. Failure to comply may result in personal injury and/or equipment damage.</p>
	<p>Caution: The evaluation or reference board contains parts and assemblies sensitive to electrostatic discharge (ESD). Electrostatic control precautions are required when installing, testing, servicing or repairing the assembly. Component damage may result if ESD control procedures are not followed. If you are not familiar with electrostatic control procedures, refer to the applicable ESD protection handbooks and guidelines.</p>
	<p>Caution: A drive that is incorrectly applied or installed can lead to component damage or reduction in product lifetime. Wiring or application errors such as undersizing the motor, supplying an incorrect or inadequate AC supply, or excessive ambient temperatures may result in system malfunction.</p>

Table of contents

	About this document	1
	Important notice	2
	Safety precautions	3
	Table of contents	4
1	The board at a glance	5
2	System and functional description	6
2.1	Getting started	6
2.2	Description of the functional blocks	7
2.3	Operation with Arduino	7
2.3.1	Blind spot indicator function	8
2.3.2	Parking sensor function	8
3	Fault detection	9
4	System design	10
4.1	Schematics	10
4.2	PCB layout	11
4.3	Bill of material	12
	References	14
	Revision history	15
	Disclaimer	16

1 The board at a glance

1 The board at a glance

TLE4241GMSHIELD is an extension board for Arduino UNO intended to evaluate 2 main applications for automotive environment (please refer to [Chapter 2.3](#)):

- Blind spot indicator
- Parking radar sensor

When connected to a properly programmed Arduino UNO board, the ultrasonic sensor (not included in the evaluation kit) will allow the user to activate the onboard LEDs when certain conditions are satisfied.

TLE4241GMSHIELD can also operate in standalone condition. In this particular case, the PWM signal of the TLE4241GM will be fixed and the LEDs will be turned on at its maximum regulated output current, as shown on the table below.

Parameter	Value	Conditions
Input voltage supply	8 V to 45 V	Standalone operation
	12 V	Arduino connected
Output current	32.5 mA	$R_{REF} = 18\text{ k}\Omega$

The output current is regulated by the resistance R_{REF} placed between the REF pin and ground.

Note: Change this resistor if different output current is needed.

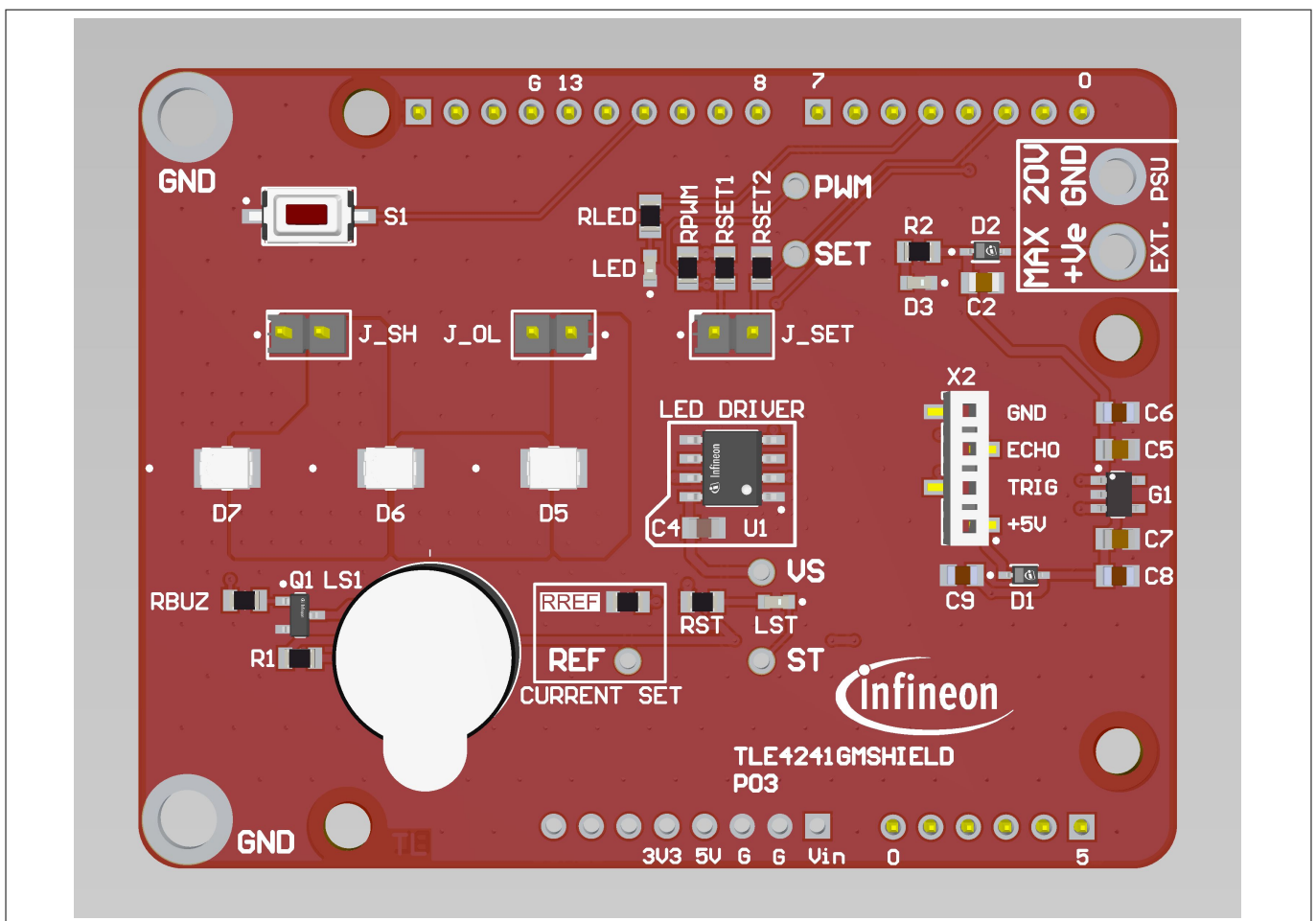

Figure 1 TLE4241SYS_SHIELD board

2 System and functional description

2 System and functional description

2.1 Getting started

The jumpers are positioned as follows when TLE4241GMSHIELD is operating both in standalone condition or is connected to Arduino UNO.

Table 2 Jumper position

Jumper number	Condition	Description
J_OL	Closed	LED load is connected to TLE4241GM output
J_SH	Open	LED load is composed of 3 LEDs
J_SET	Open	Output current analog adjustment is managed by Arduino board

The default configuration is depicted in the figure below.

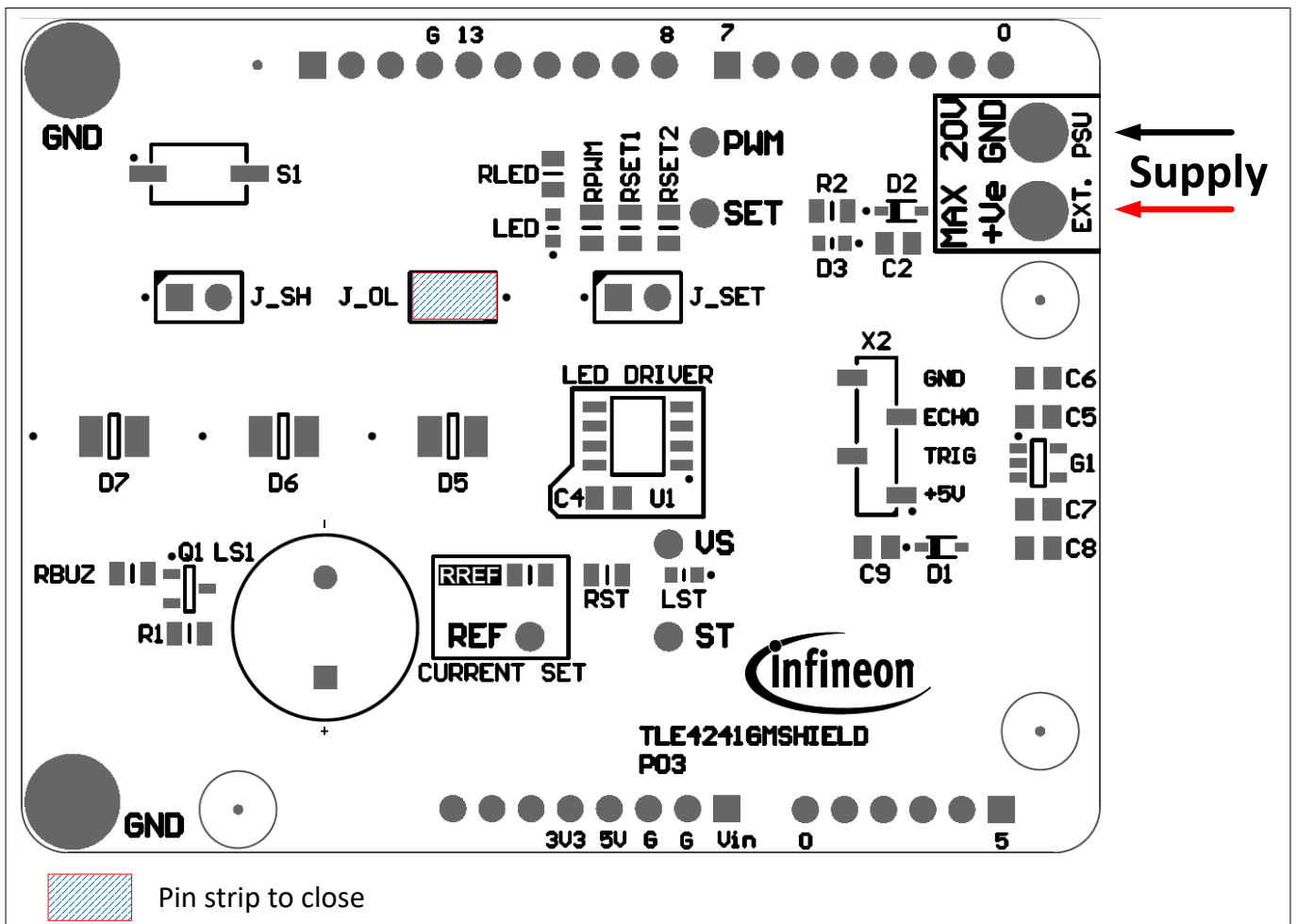

Figure 2 Default configuration of the board

2 System and functional description

2.2 Description of the functional blocks

Current adjustment

TLE4241GM output current adjustment is performed by changing the value of R_{REF} , that will set the output current level according to the following formula:

$$I_{OUT} = \frac{1.2}{R_{REF}} \times 487 + 0.1$$

On this board the resistor placed on the REF pin R_{REF} is equal to 18 kΩ. The regulated current is 32.5 mA.

2.3 Operation with Arduino

TLE4241GMSHIELD is designed to operate in conjunction with Arduino UNO board (not provided).

In this condition, TLE4241GM output current can be controlled from Arduino UNO board, that will variate PWM and SET signals. Maximum output current is anyway defined by R_{REF} resistor value.

Example code enables the user to evaluate two possible scenarios:

- Blind spot indicator
- Parking sensor

It is possible to change the scenario by clicking **on-board Scenario Selection S1 button** for 2 seconds.

On X2 on-board connector, it is possible to connect an external ultra-sound sensor (not included), to measure the distance from the board to an object. The sensor will be supplied with an on-board 5 V supply. The TRIG pin is used to initiate the distance measurement, while the ECHO pin is used to read back the distance measure from the ultra-sound module. Please refer to the silkscreen for the signal pinout.

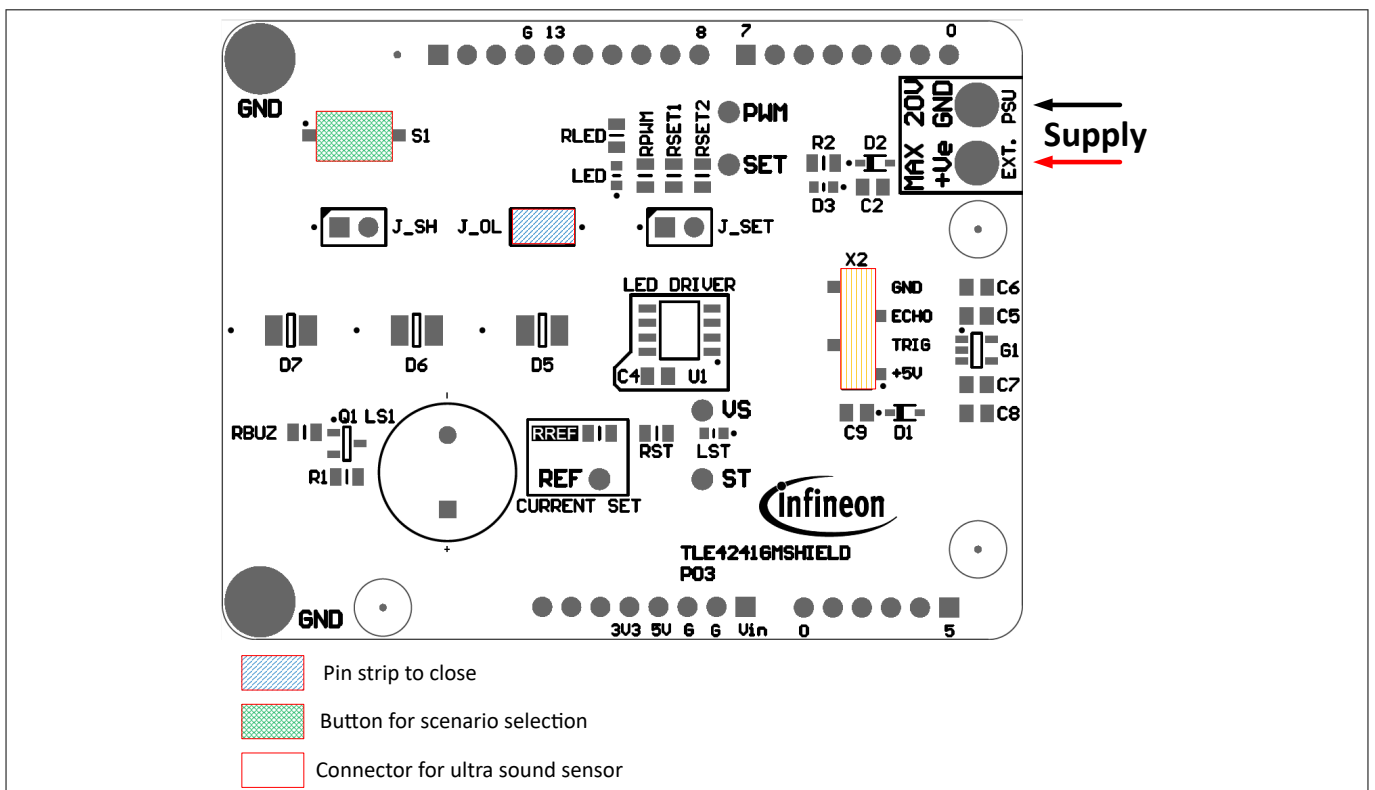

Figure 3 Button and connector for ultrasound sensor position

Note: Example code is not provided in this user guide, and can be downloaded from Infineon website.

2 System and functional description

2.3.1 Blind spot indicator function

In general, blind spot detection system is designed to assist the driver by monitoring the blind spots on both sides of the vehicle.

When blind spot indicator scenario is selected, by selecting **on-board Scenario Selection S1 button** on the board, the ultra sonic sensor detects any obstacle within 30 cm. Arduino UNO, will then raise the TLE4241GM PWM pin voltage, resulting in turning on the output channel. When the obstacle is removed, Arduino UNO will lower PWM voltage, resulting in turning off the output channel.

It is possible to modify the distance threshold when the output level is triggered changing the threshold value in the example code provided from 20 cm to 240 cm.

2.3.2 Parking sensor function

In general, the parking sensor system is designed to assist the driver by indicating with a sound and light how close to an obstacle the vehicle is when the driver parks the vehicle.

When **Parking Sensor** is selected, the ultrasonic sensor detects obstacles within the range of the detection capabilities of the used sensor.

Arduino UNO is programmed to act differently based on the detected distance from the obstacle. The frequency of the LED blinking is adjusted depending on the distance from the obstacle.

In both scenarios, the on-board buzzer is activated when an obstacle is detected.

3 Fault detection

The system has been designed to detect the following error conditions:

- Open load
- Short to GND
- Overtemperature

In each case, ST pin will be pulled LOW, and the error status will be detected to Arduino UNO board (if connected).

By using the evaluation board, it is possible to evaluate:

- An open load condition by leaving the jumper J_OL open
- A short to GND condition by closing the jumper J_SH

4 System design

4 System design

4.1 Schematics

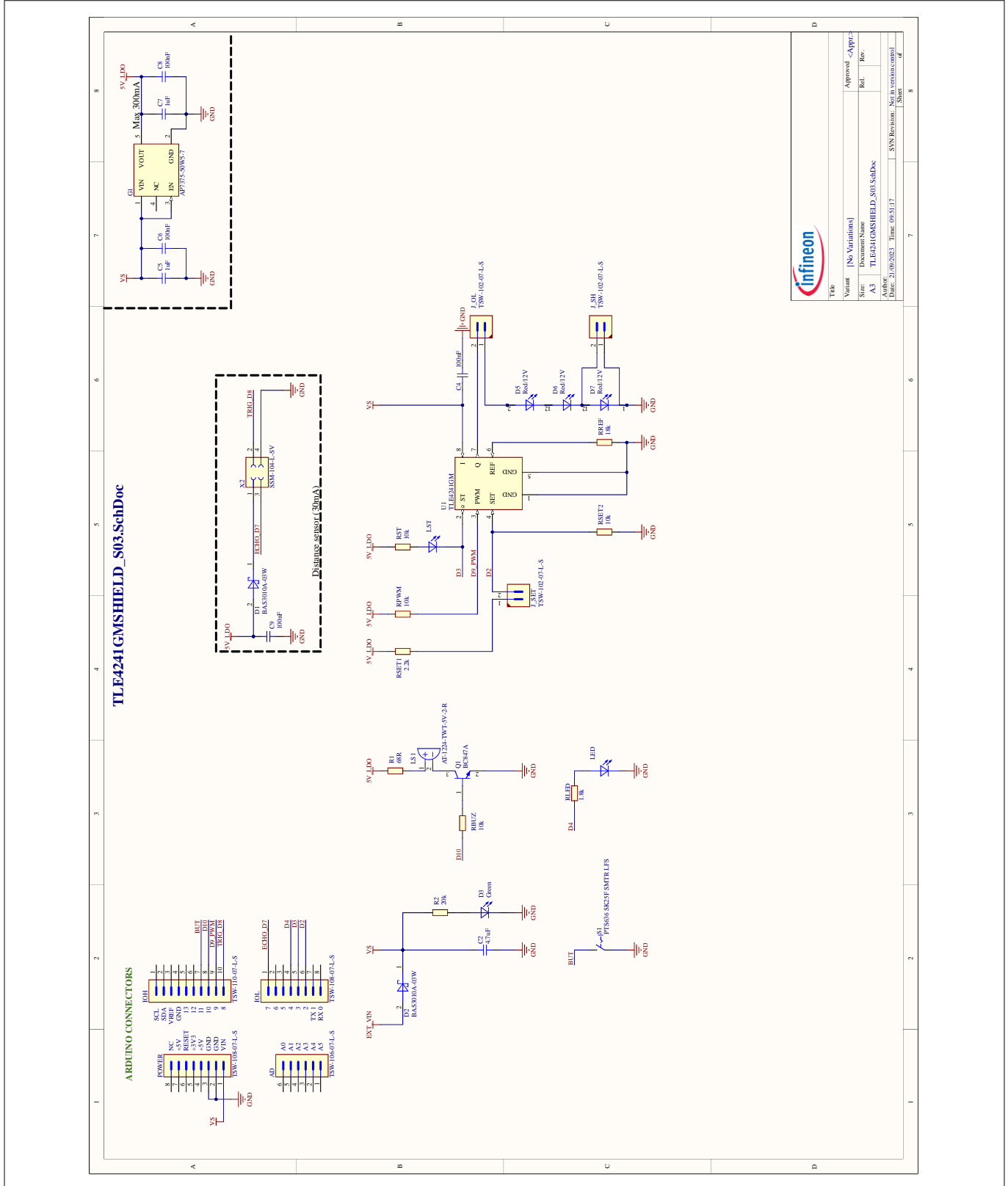

Figure 4 TLE4241GMSHIELD_S03_P03_schematic

4 System design

4.2 PCB layout

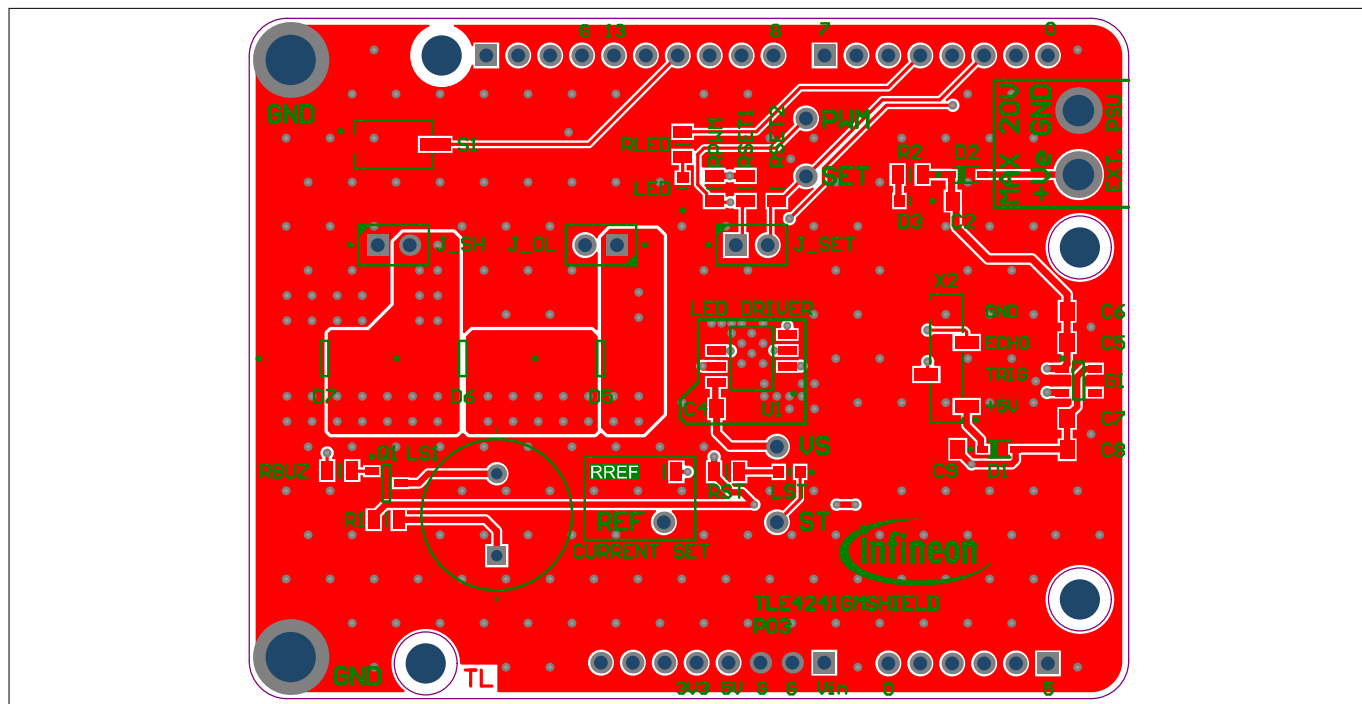

Figure 5 PCB layout top view

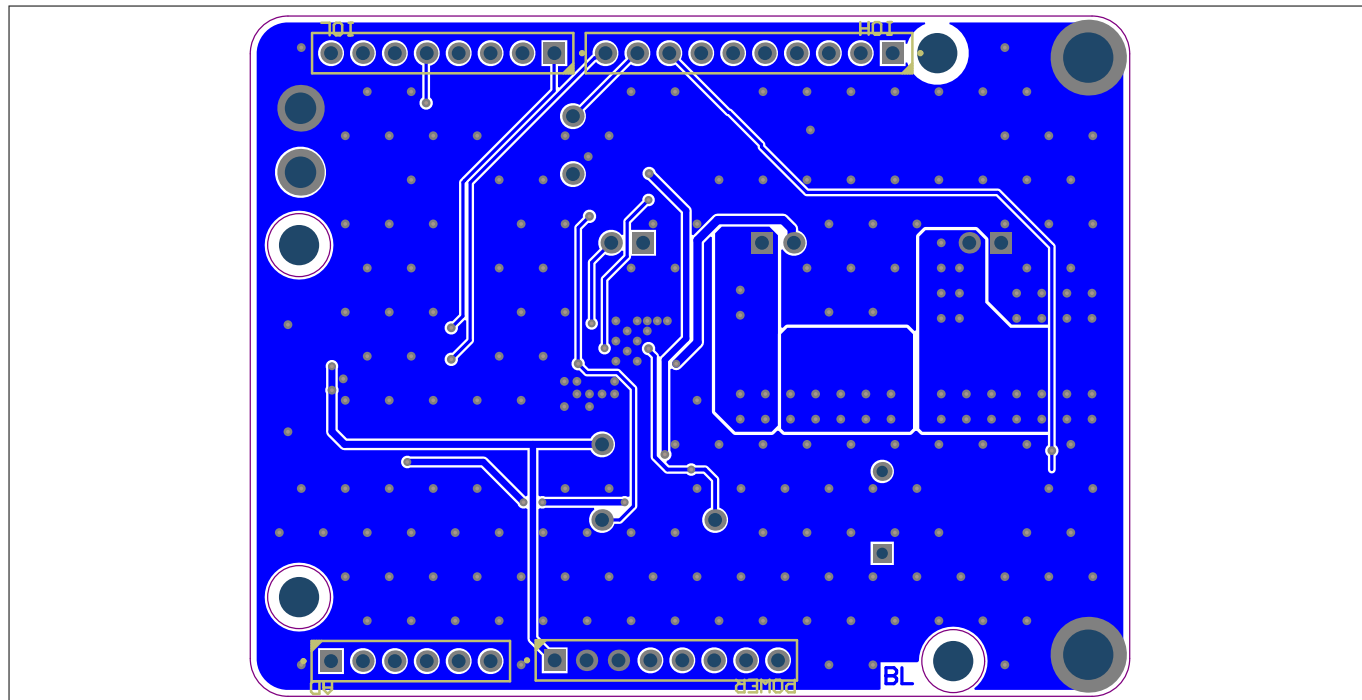

Figure 6 PCB layout bottom view - flipped horizontally

4 System design

4.3 Bill of material

Quantity	Designator	Value	Description	Manufacturer
1	AD	TSW-106-07-L-S	Through hole .025 SQ Post Header, 2.54mm pitch, 6 pin, vertical, single row	Samtec
1	C2	4.7uF	CAP/CERA / 4.7uF/25V / 10% / X7S (EIA) / -55°C to 125°C/0805(2012) / SMD / -	MuRata
1	C4	100nF	CAP / CERA / 100nF / 50V / 10% / X8R (EIA) / -55°C to 125°C / 0805 / SMD / -	AVX
2	C5, C7	1uF	CAP / CERA / 1uF / 50V / 10% / X7R (EIA) / -55°C to 125°C / 0805 / SMD / -	MuRata
3	C6, C8, C9	100nF	CAP / CERA / 100nF / 50V / 10% / X7R (EIA) / -55°C to 125°C / 805(2012) / SMD / -	AVX
2	D1, D2	BAS3010A-03W	Medium Power AF Schottky Diode	Infineon Technologies
1	D3	Green	Standard 0603 SMD LED	Vishay
3	D5, D6, D7		PowerTOPLED, 633nm Red	OSRAM Opto Semiconductors
1	G1	AP7375-50W5-7	ULDO Regulator With Wide Input Voltage Range, 300mA	Diodes Incorporated
1	IOH	TSW-110-07-L-S	Through hole .025 SQ Post Header, 2.54mm pitch, 10 pin, vertical, single row	Samtec
2	IOL, POWER	TSW-108-07-L-S	Through hole .025 SQ Post Header, 2.54mm pitch, 8 pin, vertical, single row	Samtec
3	J_OL, J_SET, J_SH	TSW-102-07-L-S	Through hole .025" SQ Post Header, 2.54mm pitch, 2 pin, vertical, single row	Samtec
2	LED, LST		Low Current 0603 SMD LED	Vishay
1	LS1	WST-0906T	Internally Driven Electro Magnetic Buzzer, 5V, 30mA, 2.7kHz	Soberton
1	Q1	BC847A	NPN Silicon AF Transistor	Infineon Technologies
1	R1	68R	RES / STD / 68R / 125mW / 1% / 100ppm/K / -55°C to 155°C / 0805(2012) / SMD / -	Vishay
1	R2	20k	RES / STD / 20k / 125mW / 1% / 100ppm/K / -55°C to 155°C / 0805(2012) / SMD / -	Vishay
4	RBUZ, RPWM, RSET2, RST	10k	RES / STD / 10k / 125mW / 1% / 100ppm/K / -55°C to 155°C / 0805(2012) / SMD / -	Vishay
1	RLED	1.8k	RES / STD / 1.8k / 125mW / 1% / 100ppm/K / -55°C to 155°C / 0805(2012) / SMD / -	Vishay
1	RREF	18k	RES / STD / 18k / 125mW / 1% / 100ppm/K / -55°C to 155°C / 0805(2012) / SMD / -	Vishay
1	RSET1	2.2k	RES / STD / 2.2k / 125mW / 1% / 100ppm/K / -55°C to 155°C / 0805(2012) / SMD / -	Vishay

4 System design

Quantity	Designator	Value	Description	Manufacturer
1	S1	PTS636 SK25F SMTR LFS	Tactile Switches With Home Automation And Remote Control, 12V	C&K
1	U1	TLE4241GM	Adjustable Current LITIX Linear	Infineon Technologies
1	X2	SSM-104-L-SV	Tiger Claw Surface Mount Socket, 4Pin	Samtec

References

- [1] Infineon *TLE4241GM* datasheet; <https://www.infineon.com/cms/en/product/power/lighting-ics/litix-automotive-led-driver-ic/litix-linear/tle4241gm/#!documents>

Revision history

Document version	Date of release	Description of changes
Rev.1.00	2023-10-23	<ul style="list-style-type: none">Initial document release

Trademarks

All referenced product or service names and trademarks are the property of their respective owners.

Edition 2023-10-23

Published by

Infineon Technologies AG

81726 Munich, Germany

© 2023 Infineon Technologies AG

All Rights Reserved.

Do you have a question about any aspect of this document?

Email: erratum@infineon.com

Document reference

IFX-dqw1691744322165

For further information on the product, technology, delivery terms and conditions and prices please contact your nearest Infineon Technologies office (www.infineon.com)

Warnings

Due to technical requirements products may contain dangerous substances. For information on the types in question please contact your nearest Infineon Technologies office.

Except as otherwise explicitly approved by Infineon Technologies in a written document signed by authorized representatives of Infineon Technologies, Infineon Technologies' products may not be used in any applications where a failure of the product or any consequences of the use thereof can reasonably be expected to result in personal injury.

Mouser Electronics

Authorized Distributor

Click to View Pricing, Inventory, Delivery & Lifecycle Information:

[Infineon:](#)

[TLE4241SYSSHIELDTOBO1](#)