

Self-Protected Very Low I_Q High Side Driver with Analog Current Sense

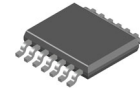

TSSOP14 EP
CASE 948BZ

Product Preview NCV84003F

The NCV84003F is a fully protected single channel high side driver that can be used to switch a wide variety of loads, such as bulbs, solenoids, and other actuators. The device incorporates advanced protection features such as active inrush current management, over-temperature shutdown with latch-off. A dedicated Current Sense pin provides precision analog current monitoring of the output as well as fault indication in case of output short circuit to Supply, overload, over-temperature, OUT short circuit to GND, and OFF state open load detection. A Diagnostic Enable pin allows all diagnostic and current sense features to be enabled or disabled during device operation.

Features

- 5 V/3.3 V Compatible Control Input
- Low Standby Current
- Absolute and Differential Thermal Shutdown
- Proportional Analog Current Sense Output Multiplexed with Discrete Output Levels for Fault Differentiation
- Overload and Short to Ground Protection with Active Inrush Management
- Intelligent Retry with Latch Off in Protect Mode
- OFF State Open Load (OSOL) and Short Circuit to V_{BATT} Detection
- Under-voltage Shutdown and Over-voltage Protection
- Protection against Loss of Ground and Loss of V_{BATT}
- Inverse Current Protection with FET Turn On in Inverse Mode
- ESD Protection
- Reverse Battery Protection with External Components
- AEC-Q100 Qualified and PPAP Capable

Typical Applications

- Switch a Variety of Resistive, Inductive and Capacitive Loads
- Can Replace Electromechanical Relays, Discrete
- Circuits and Fuses
- Automotive / Industrial

FEATURE SUMMARY

Nominal Operating Voltage Range	V _D	6 to 18	V
R _{DSon} T _J = 25°C	R _{ON}	3	mΩ
Output Current Limit (Typ)	I _{lim}	125	A
Quiescent Current	I _{Q_85}	0.5	μA

This document contains information on a product under development. onsemi reserves the right to change or discontinue this product without notice.

MARKING DIAGRAM

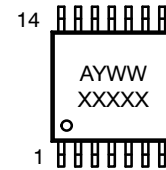

XXXXX = Specific Device Code
A = Assembly Location
Y = Year
WW = Work Week

PACKAGE PIN DESCRIPTION

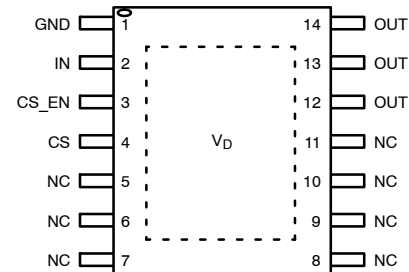

(Top View)

PIN DESCRIPTION

Pin #	Symbol	Description
1	GND	Ground Reference
2	IN	Logic Level Input for Output Activation
3	CS_EN	Logic Level Input for Diagnosis Enable
4	CS	Current Sense/Diagnostic Output
5-11	NC	No Connect
12-14	OUT	Output
E-pad	V _D	Drain Pin Supply Voltage

ORDERING INFORMATION

Device	Package	Shipping [†]
NCV84003F	TSSOP14-EP (Pb-Free)	TBD

[†]For information on tape and reel specifications, including part orientation and tape sizes, please refer to our Tape and Reel Packaging Specifications Brochure, BRD8011/D.

NCV84003F

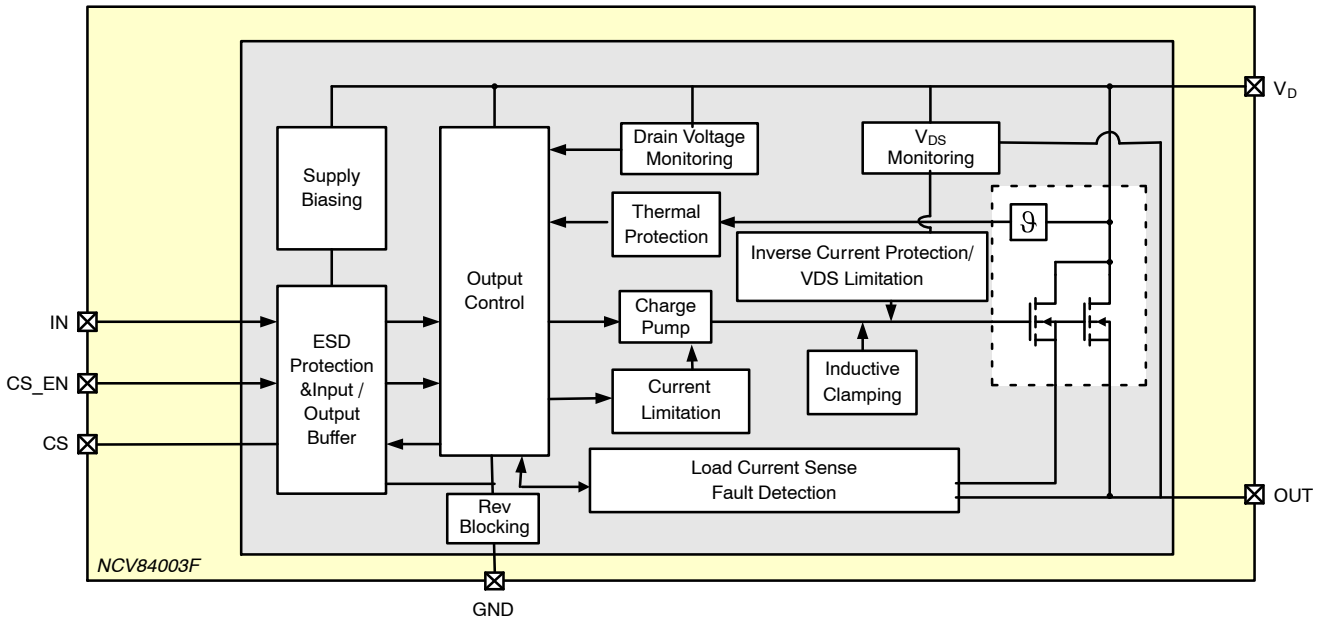

Figure 1. Block Diagram

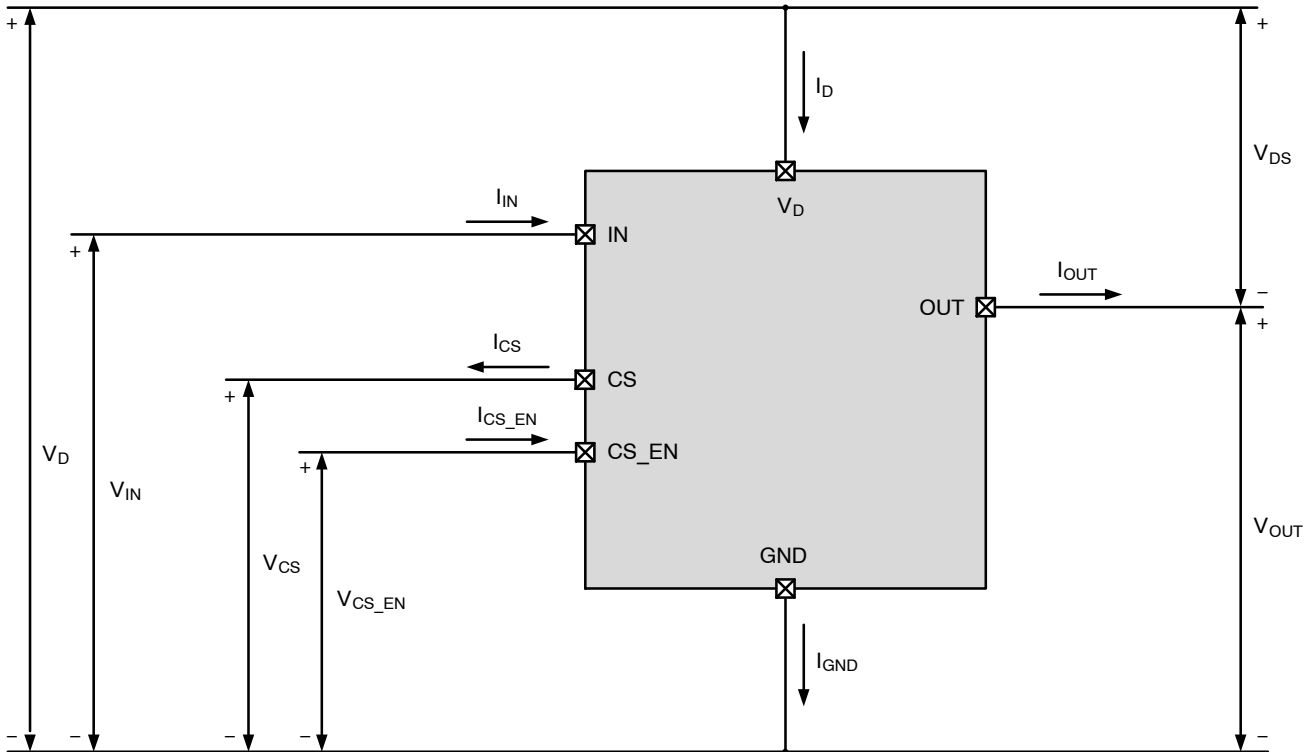

Figure 2. Voltage and Current Definitions

ELECTRICAL SPECIFICATIONS

Table 1. MAXIMUM RATINGS (Note 1) ($-40^{\circ}\text{C} \leq T_J \leq 150^{\circ}\text{C}$ unless otherwise specified)

Symbol	Rating	Min	Max	Unit
GENERAL				
V_D	Supply Voltage	-0.3	28	V
V_{D_LD}	Supply Voltage for Load Dump Protection	-	35	V
V_{D_SC}	Supply Voltage for Short Circuit Protection	0	24	V
V_{D_REV}	Reverse Polarity Voltage, $t < 2$ min, Load: 2Ω , Setup: Refer to Figure 15	-16	0	V
SHORT CIRCUIT CAPABILITY				
RSC	Repetitive Short Circuit Capability per AEC Q100-12, LSC and TSC, 100 ppm, 300 ms	-	1000	k cycles
INPUT PINS: IN, CS_EN				
$I_{DIG_IN_MAX}$	Current at Input Pins	-1	2	mA
$I_{DIG_IN_MAX_REV}$	Current at Input Pins in Rev Battery, $t < 2$ min	-1	10	mA
$V_{DIG_IN_MAX}$	Voltage at Input Pins	-0.3	6.5	V
CURRENT SENSE OUTPUT				
V_{CS_MAX}	Voltage at Current Sense Output	-0.3	V_D	V
I_{CS_MAX}	Current at Current Sense Output	-25	$I_{CS(SAT)}$	mA
OUTPUTS				
P_{MAX}	Power Dissipation $T_A = 85^{\circ}\text{C}$, $T_J = 150^{\circ}\text{C}$	-	TBD	W
V_{DS_MAX}	Drain-Source Voltage at Power Transistor	-	V_{ZCL}	V
E_{AS}	Single Pulse Inductive Load Switching Energy ($L = \text{TBD mH}$, $V_D = 13.5 \text{ V}$, $I_L = 6 \text{ A}$, $T_{JSTART} = 150^{\circ}\text{C}$)	TBD	-	mJ
GROUND TERMINAL				
I_{GND}	Current through GND Pin	-50	50	mA
TEMPERATURES				
T_J	Operating Junction Temperature	-40	150	$^{\circ}\text{C}$
$T_{J_storage}$	Storage Temperature	-55	150	$^{\circ}\text{C}$
ESD				
V_{ESD_HBM}	ESD Susceptibility All Pins HBM	-2	+2	kV
$V_{ESD_OUT_HBM}$	ESD Susceptibility OUTx to GND, V_D Connected, HBM	-4	4	kV
V_{ESD_CDM}	ESD Susceptibility All Pins CDM	-500	500	V
V_{ESD_NC}	ESD Susceptibility Pin (Corner Pins), CDM	-750	750	V

Stresses exceeding those listed in the Maximum Ratings table may damage the device. If any of these limits are exceeded, device functionality should not be assumed, damage may occur and reliability may be affected.

1. Not subject to production testing.

Table 2. THERMAL RESISTANCE RATINGS

Symbol	Parameter	Max Value	Unit
P_{si_JT}	Thermal Resistance Junction-to-Top (Note 2)	TBD	°C/W
P_{si_e-PAD}	Junction-to-EPAD (Note 2)	TBD	°C/W
R_{thJA}	Junction-to-Ambient - 1s0p min pad (Note 2)	TBD	°C/W
R_{thJA}	Junction-to-Ambient - 1s0p + 1 in ² Cu (Note 2)	TBD	°C/W
R_{thJA}	Junction-to-Ambient - 2s2p min pad (Note 3)	TBD	°C/W
R_{thJA}	Junction-to-Ambient - 2s2p + 1 in ² Cu (Note 3)	TBD	°C/W

- Board construction based on JEDEC JESD 51-3 for a single layer 1s0p board with forced air convection.
- Board construction based on JEDEC JESD 51-7 for a four layer 2s2p board with forced air convection. Vias were added under the exposed pad as shown below.

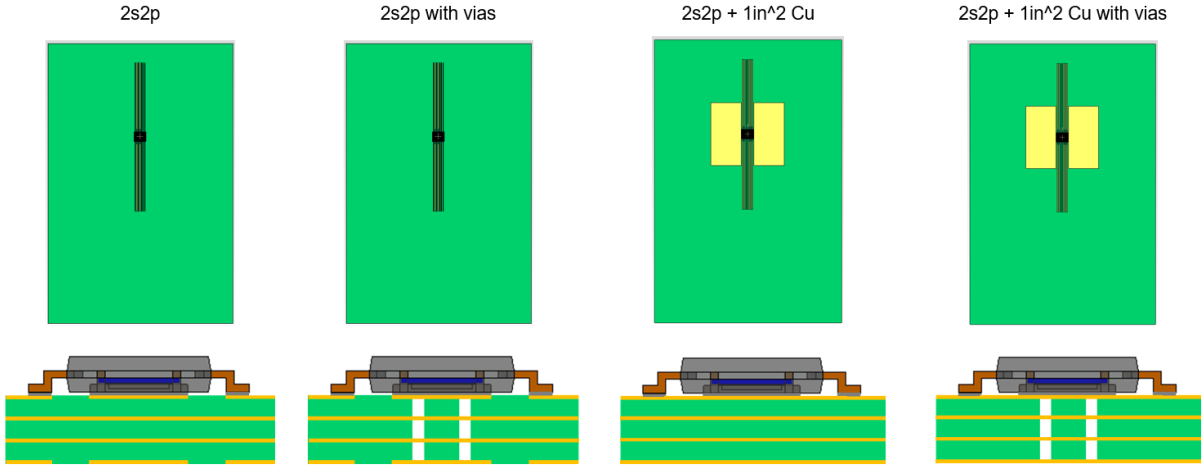

Figure 3. Board Construction for Thermal Performance

NCV84003F

Table 3. ELECTRICAL CHARACTERISTICS ($6 \leq V_D \leq 18 \text{ V}$; $-40^\circ\text{C} \leq T_J \leq 150^\circ\text{C}$ unless otherwise specified)
(Typical Values measured @ $V_D = 13.5 \text{ V}$, $T_J = 25^\circ\text{C}$)

Symbol	Rating	Conditions	Min	Typ	Max	Unit
SUPPLY						
V_{D_NOM}	Nominal Supply Voltage Range (Note 4)		6	13.5	18	V
V_{DS_EX}	Extended Supply Voltage Range (Notes 4, 5)	$V_{IN} = 5 \text{ V}$, $R_L = 4 \Omega$, $3.1 \text{ V} \leq V_D \leq 28 \text{ V}$ Ramp down V_D from 28 V to 3.1 V	-	-	0.5	V
V_{D_UV}	Under Voltage Shutdown	$V_{IN} = 5 \text{ V}$, V_D Falling, From $V_{DS} < 0.5 \text{ V}$ to $I_{OUT} = 0$	2.4	2.9	3.1	V
V_{D_MIN}	Minimum Operating Voltage	$V_{IN} = 5 \text{ V}$, V_D Rising, From $I_{OUT} = 0$ to $V_{DS} < 0.5 \text{ V}$	2.9	3.4	4.1	V
$V_{D_UV_HYS}$	Under Voltage Shutdown Hysteresis		-	0.5	-	V
$t_{UV_Recover}$	Supply Undervoltage Recovery Time (Note 4)	$V_{IN} = 5 \text{ V}$, V_D Rising, From $V_D = 0 \text{ V} \rightarrow V_D \geq V_{D_MIN}$ to $V_{DS} < 0.5 \text{ V}$ (See Figure 13)	2.5	5	7.5	ms
I_{Q_85}	Quiescent Current	$V_D = 18 \text{ V}$, $T_J \leq 85^\circ\text{C}$, $V_{IN} = V_{CS_EN} = 0 \text{ V}$	-	10	500	nA
I_{Q_150}	Quiescent Current	$V_D = 18 \text{ V}$, $T_J = 150^\circ\text{C}$, $V_{IN} = V_{CS_EN} = 0 \text{ V}$	-	5	20	μA
I_{Q_DIAG}	Quiescent Current, Diagnostic Active	$V_D = 18 \text{ V}$, $V_{IN} = 0 \text{ V}$, $V_{CS_EN} = 5 \text{ V}$	-	1.8	2.4	mA
I_{GND_ON}	Normal Operating Current	$V_D = 18 \text{ V}$, $V_{IN} = V_{CS_EN} = 5 \text{ V}$, $V_{CS} < 5 \text{ V}$	-	3	4	mA
POWER OUTPUT						
R_{ON_25}	On-state Resistance	$I_{OUT} = I_{NOM} = 15 \text{ A}$, $V_{IN} = 5 \text{ V}$, $T_J = 25^\circ\text{C}$	-	3	-	$\text{m}\Omega$
R_{ON_150}	On-state Resistance	$I_{OUT} = I_{NOM} = 15 \text{ A}$, $V_{IN} = 5 \text{ V}$, $T_J = 150^\circ\text{C}$	-	-	6	$\text{m}\Omega$
R_{ON_LV}	On-state Resistance–Low Voltage	$I_{OUT} = 2 \text{ A}$, $V_D = 3.4 \text{ V}$, $T_J = 150^\circ\text{C}$	-	-	8	$\text{m}\Omega$
$R_{ON_INV_25}$	On-state Resistance–Inverse Current	$I_{OUT} = -4 \text{ A}$, $V_D = 13.5 \text{ V}$, $T_J = 25^\circ\text{C}$	-	3	-	$\text{m}\Omega$
$R_{ON_INV_150}$	On-state Resistance–Inverse Current	$I_{OUT} = -4 \text{ A}$, $V_D = 13.5 \text{ V}$, $T_J = 150^\circ\text{C}$	-	-	6	$\text{m}\Omega$
I_{LEAK_85}	Output Leakage Current	$V_{IN} = V_{CS_EN} = 0 \text{ V}$, $V_{OUT} = 0 \text{ V}$, $T_J < 85^\circ\text{C}$	-	-	0.5	μA
I_{LEAK_150}	Output Leakage Current	$V_{IN} = V_{CS_EN} = 0 \text{ V}$, $V_{OUT} = 0 \text{ V}$, $T_J < 150^\circ\text{C}$	-	-	15	μA
V_{ZCL}	Drain-to-Source Clamping Voltage ($V_D - V_{OUT}$)	$I_{OUT} = 20 \text{ mA}$, $V_{IN} = 0 \text{ V}$	35	36	39	V
V_F	Body Diode Forward Voltage	$I_{OUT} = -1 \text{ A}$, $T_J = 150^\circ\text{C}$, $V_F = V_{out} - V_D$	-	-	0.7	V
$ dV_{OUT}/dt $	OUT slew in H-Bridge Configuration (Note 4)		-	-	10	$\text{V}/\mu\text{s}$

Product parametric performance is indicated in the Electrical Characteristics for the listed test conditions, unless otherwise noted. Product performance may not be indicated by the Electrical Characteristics if operated under different conditions.

4. Not subject to production testing.

5. Extended operation outside the nominal supply voltage range may affect device reliability. Parametric performance not guaranteed.

INPUT PINS

All low-voltage control inputs are compatible with 3.3 V and 5 V microcontroller supply voltages. All inputs comprise of a voltage Schmidt-trigger circuit to enable direct drive from voltage sources and prevent uncontrolled

oscillations due to slow transitions at the inputs. Each input features a pull-down element to prevent uncontrolled input states in case of an open pin condition. Unused inputs should be left open or connected to device GND through a 4.7 kΩ resistor.

Table 4. DIGITAL INPUT (IN, CS_EN) CHARACTERISTICS ($6 \leq V_D \leq 18 \text{ V}$; $-40^\circ\text{C} \leq T_J \leq 150^\circ\text{C}$ unless otherwise specified)

Symbol	Rating	Conditions	Min	Typ	Max	Unit
V _{DIG_IN_L}	Low Level Digital Input Voltage		–	–	0.8	V
V _{DIG_IN_H}	High Level Digital Input Voltage		2	–	–	V
V _{DIG_IN_HYS}	Digital Input Voltage Hysteresis		–	0.25	–	V
I _{IN_PD}	Digital Input Pull-down Current	$0.8 \text{ V} \leq V_{IN} \leq 2 \text{ V}$	1	–	25	μA

Table 5. SWITCHING CHARACTERISTICS ($6 \leq V_D \leq 18 \text{ V}$; $-40^\circ\text{C} \leq T_J \leq 150^\circ\text{C}$ unless otherwise specified) (Refer to Figure 7)

Symbol	Rating	Conditions	Min	Typ	Max	Unit
t _{D_ON}	Turn ON Delay (V _{IN} Lo → Hi to V _{OUT} = 10% V _D)	V _D = 13.5 V, R _L = 2 Ω	20	70	140	μs
t _{ON}	Turn ON Time (V _{IN} Lo → Hi to V _{OUT} = 90% V _D)		50	130	200	μs
t _{D_OFF}	Turn OFF Delay (V _{IN} Hi → Lo to V _{OUT} = 90% V _D)		50	130	200	μs
t _{OFF}	Turn OFF Time (V _{IN} Hi → Lo to V _{OUT} = 10% V _D)		30	100	200	μs
Δt _{ON-OFF}	Turn ON / OFF Matching t _{ON} – t _{OFF}		–20	20	60	μs
SR _{ON}	Slew Rate ON (V _{OUT} = 30% to 70% V _D)		0.15	0.3	0.45	V/μs
SR _{OFF}	Slew Rate OFF (V _{OUT} = 70% to 30% V _D)		–0.45	–0.3	–0.15	V/μs
ΔnSR	Slew Rate Matching SR _{ON} – SR _{OFF}	–0.15	0	0.15	V/μs	
W _{ON}	Turn ON Energy (Note 6)	V _D = 18 V, R _L = 4 Ω, V _{OUT} : 10% V _D ↔ 90% V _D	–	0.3	–	mJ
W _{OFF}	Turn OFF Energy (Note 6)		–	0.3	–	mJ

6. Not Subject to Production Testing.

PROTECTION

Table 6. PROTECTION CHARACTERISTICS ($6 \leq V_D \leq 18$ V; $-40^\circ\text{C} \leq T_J \leq 150^\circ\text{C}$ unless otherwise specified)

Symbol	Parameter Characteristic	Conditions	Min	Typ	Max	Unit
$I_{LIM(-40C)}$	Current Limitation	$V_D = 15$ V, Setup based on AECQ100-012 Load Short Circuit	112	130	138	A
$I_{LIM(25C)}$	Current Limitation (Note 7)	$V_D = 15$ V, Setup based on AECQ100-012 Load Short Circuit	112	130	138	A
$I_{LIM(150C)}$	Current Limitation (Note 7)	$V_D = 15$ V, Setup based on AECQ100-012 Load Short Circuit	112	130	138	A
$I_{LIM(FB)}$	Current Limitation at High V_{DS} (Note 7)	$V_{DS} \geq 17$ V	-	$0.6 \times I_{LIM}$	-	A
$I_{LIM(JS)}$	Current Limitation at High V_D for Jump Start (Note 7)	$V_D > V_{D_JS}$	-	$0.6 \times I_{LIM}$	-	A
T_{DTSD}	Dynamic Temperature Swing Threshold (Note 7)		-	80	-	$^\circ\text{C}$
T_{TSD}	Thermal Shutdown Temperature Threshold (Note 7)		150	175	200	$^\circ\text{C}$
T_{TSD_HYS}	Thermal Shutdown Temperature Hysteresis (Note 7)		-	20	-	$^\circ\text{C}$
V_{ZOV}	Over-Voltage Protection Clamp	$I_{OUT} = 5$ mA, $V_{IN} = 0$ V	35	36	39	V
V_{D_JS}	Drain Voltage for Current Limitation Reduction in Jump Start (Note 7)		20.5	22.5	24	V

7. Not Subject to Production Testing.

Table 7. RETRY STRATEGY (Refer to Figure 19)

Symbol	Parameter Characteristic	Conditions	Min	Typ	Max	Unit
n_{COUNT}	Number of Retries in Fault after Counter Reset (Note 8)	$I_{OUT} = I_{LIM}$, or $T_{J(ABS)} > T_{TSD}$, or $T_{J(DYN)} > \Delta T_J$	-	1	-	
$t_{IN(Rst)}$	EN Based Counter Reset Time (Note 8)		40	70	100	ms
$t_{CS_EN(Rst)}$	CS_EN Based Counter Reset Time (Note 8)	$V_{IN} = 0$ V, Fault Counter > 0	150	200	250	μs

8. Not Subject to Production Testing.

DIAGNOSTIC FUNCTIONS

NCV84003F provides diagnostic information and dynamic current sensing on the diagnostic output pin CS.

Table 8. DIAGNOSTIC TRUTH TABLE

Operation Mode	IN	CS_EN	Output Voltage	CS Output	
Normal Operation	L	H	~GND	HiZ, if Fault Counter = 0 I _{CS_FAULT} if Fault Counter > 0	
Short Circuit to GND			GND	HiZ, if Fault Counter = 0 I _{CS_FAULT} if Fault Counter > 0	
Over Temperature			~GND	HiZ, if Fault Counter = 0 I _{CS_FAULT} if Fault Counter > 0	
Short Circuit to V _{BATT}			V _{BATT}	I _{CS_OSOL} , if Fault Counter = 0 I _{CS_FAULT} if Fault Counter > 0	
Open Load			< V _D - V _{OL_OFF}	HiZ, if Fault Counter = 0 I _{CS_FAULT} if Fault Counter > 0	
			> V _D - V _{OL_OFF}	I _{CS_OSOL} , if Fault Counter = 0 I _{CS_FAULT} if Fault Counter > 0	
Inverse Current			> V _D	I _{CS_OSOL} , if Fault Counter = 0 I _{CS_FAULT} if Fault Counter > 0	
Normal Operation			H	~V _D	I _{CS} = I _{OUT} / K _{NOM}
Current Limitation				< V _D	I _{CS_FAULT}
Short Circuit to GND				~GND	I _{CS_FAULT}
Over Temperature (Absolute or Dynamic)	~GND	I _{CS_FAULT}			
Short Circuit to V _{BATT}	V _{BATT}	I _{CS} < I _{OUT} / K _{NOM}			
Open load	~V _D	I _{CS} ≤ I _{CS(OL)}			
Underload	~V _D	I _{CS_OL} < I _{CS} < I _{OUT} / K			
Inverse Current	> V _D	I _{CS} ≤ I _{CS(OL)}			
Diagnostics Disabled	X	L	X	HiZ	

NCV84003F

CURRENT SENSE RATIO

The accuracy of IO_{UT} to ICS ratio (K), can be improved by a calibration procedure in end of line testing. The procedure can be performed at nominal current at a single designated temperature.

DIAGNOSTICS

Table 9. CURRENT SENSE CHARACTERISTICS ($6 \leq V_D \leq 18 \text{ V}$; $-40^\circ\text{C} \leq T_J \leq 150^\circ\text{C}$ unless otherwise specified)

Symbol	Rating	Conditions	Min	Typ	Max	Unit
I _{Q_CS_DIS}	CS Leakage Current, CS Output Disabled	V _{IN} = 5 V, V _{CS_EN} = 0 V, I _L = 15 A	–	–	0.5	μA
I _{Q_CS_EN}	CS Leakage Current, CS Output Enabled	V _{IN} = 5 V, V _{CS_EN} = 5 V, I _L = 0 A	–	–	1	μA
V _{CS_SAT(NOM)}	CS Operation Voltage for Nominal Operation (Note 9)	V _D = 6 V, V _{IN} = V _{CS_EN} = 5 V, I _L = 15 A, I _{CS} > 0.5 × I _{CS_NOM}	0	0.5	1	V
V _{CS_SAT(Fault)_ILIM}	CS Operation Voltage for In-fault Operation (Note 9)	V _D = 6 V, V _{IN} = V _{CS_EN} = 5 V, I _{CS} > 0.5 × I _{CS_Fault_ILIM}	0	0.5	1	V
V _{CS_SAT(Fault)_TSD}	CS Operation Voltage for In-fault Operation (Note 9)	V _D = 6 V, V _{IN} = V _{CS_EN} = 5 V, I _{CS} > 0.5 × I _{CS_Fault_TSD}	0	0.5	1	V
V _{CS_SAT(OSOL)}	CS Operation Voltage for OFF State Open Load Operation (Note 9)	V _D = 6 V, V _{IN} = 0 V, V _{CS_EN} = 5 V, I _L = 0 A, I _{CS} > 0.5 × I _{CS_Fault_OSOL}	0	0.5	1	V
I _{CS_SAT}	CS Saturation Current (Note 10)		8	–	–	mA
I _{CS_FAULT_ILIM}	CS Fault Indication Current: ILIM (Note 9)	V _{IN} = 5 V, V _{CS_EN} = 5 V, Fault Counter > 0, I _{OUT} = I _{LIM}	6.7	8.5	10	mA
I _{CS_FAULT_TSD}	CS Fault Indication Current: TSD/DTSD (Note 9)	V _{IN} = 5 V, V _{CS_EN} = 5 V, Fault Counter > 0, T _J > T _{TSD} or T _{J(DYN)} > ΔT _J	3.8	5	6.5	mA
I _{CS_FAULT_OSOL}	CS Fault Indication Current in OFF State Open Load	V _{IN} = 0 V, V _{CS_EN} = 5 V, Fault Counter = 0, V _{DS} < V _{OL_OFF}	1.9	2.5	3.5	mA
V _{CS_CL}	CS Pin Clamp to Power Supply	I _{CS} = 1 mA	35	36	39	V
K ₁	Current Sense Ratio 1	I _{OUT} = 0.5 A	14000	20000	26000	
K ₂	Current Sense Ratio 2	I _{OUT} = 0.75 A	16000	20000	24000	
K ₃	Current Sense Ratio 3	I _{OUT} = 2 A	18000	20000	22000	
K ₄	Current Sense Ratio 4	I _{OUT} = 8.5 A	19000	20000	21000	
K ₅	Current Sense Ratio 5	I _{OUT} = 15 A	19400	20000	20600	
K _{rel4}	Max Current Sense Ratio Drift after Two-Point Calibration (Note 11)	K ₃ / K ₄ , including temperature drift	0.97	1	1.03	

9. Not Subject to production testing.

10. Guaranteed by Design.

11. Not subjected to production testing. For more information, refer to the [AND9733/D](#) Applications Note.

NCV84003F

Table 10. CURRENT SENSE TIMING ($6 \leq V_D \leq 18 \text{ V}$; $-40^\circ\text{C} \leq T_J \leq 150^\circ\text{C}$ unless otherwise specified)

Symbol	Rating	Conditions	Min	Typ	Max	Unit
$t_{S_CS_ENH}$	Current Sense Settling Time after Diagnostic Activation, Stable Output and Load Conditions- Nominal Load	$V_{IN} = 5 \text{ V}$, $V_{CS_EN} = 0 \text{ V} \rightarrow 5 \text{ V}$, $V_D = 13.5 \text{ V}$, $I_L = 15 \text{ A}$, $I_{CS} = 90\% I_{CS_STATIC}$, $R_{CS} = 1.2 \text{ k}\Omega$, $C_{CS} < 100 \text{ pF}$	-	-	20	μs
$t_{S_CS_ENL}$	Current Sense Settling Time after Diagnostic Activation, Stable Output and Load Conditions- Light Load (Note 12)	$V_{IN} = 5 \text{ V}$, $V_{CS_EN} = 0 \text{ V} \rightarrow 5 \text{ V}$, $V_D = 13.5 \text{ V}$, $I_L = 0.75 \text{ A}$, $I_{CS} = 90\% I_{CS_STATIC}$, $R_{CS} = 1.2 \text{ k}\Omega$, $C_{CS} < 100 \text{ pF}$	-	-	60	μs
$t_{S_CS_LOAD_U}$	Current Sense Settling Time after Load Current Change (Note 12)	$V_{IN} = V_{CS_EN} = 5 \text{ V}$, $V_D = 13.5 \text{ V}$, $I_L = 8.5 \text{ A} \rightarrow 15 \text{ A}$, $I_{CS} = 90\% I_{CS_STATIC}$, $R_{CS} = 1.2 \text{ k}\Omega$, $C_{CS} < 100 \text{ pF}$	-	-	20	μs
$t_{S_CS_LOAD_D}$	Current Sense Settling Time after Load Current Step Down to Light Load (Note 12)	$V_{IN} = V_{CS_EN} = 5 \text{ V}$, $V_D = 13.5 \text{ V}$, $I_L = 15 \text{ A} \rightarrow 0.75 \text{ A}$, $I_{CS} = 90\% I_{CS_STATIC}$, $R_{CS} = 1.2 \text{ k}\Omega$, $C_{CS} < 100 \text{ pF}$	-	-	400	μs
$t_{S_CS_DIS}$	Current Sense Output Disable Time (Note 12)	$V_{IN} = 5 \text{ V}$, $V_{CS_EN} = 5 \text{ V} \rightarrow 0 \text{ V}$, $V_D = 13.5 \text{ V}$, $I_L = 15 \text{ A}$, $I_{CS} = 10\% I_{CS_STATIC}$, $R_{CS} = 1.2 \text{ k}\Omega$, $C_{CS} < 100 \text{ pF}$	-	-	20	μs
$t_{S_CS_DIS_F}$	Current Sense Output Disable Time - In Fault (Note 12)	$V_{IN} = 0 \text{ V}$, $V_{CS_EN} = 5 \text{ V} \rightarrow 0 \text{ V}$, $V_D = V_{OUT} = 13.5 \text{ V}$, $I_{CS} = 10\% I_{CS_STATIC}$, $R_{CS} = 1.2 \text{ k}\Omega$, $C_{CS} < 100 \text{ pF}$	-	-	20	μs
t_{Fault_Blank}	Current Sense ON State Fault Blanking Time (Note 12)	$V_{IN} = 5 \text{ V}$, $V_{CS_EN} = 5 \text{ V}$, $V_D = 13.5 \text{ V}$, $R_{CS} = 1.2 \text{ k}\Omega$, $C_{CS} < 100 \text{ pF}$	-	150	-	μs

12. Not Subject to production testing.

Table 11. OPEN LOAD / UNDERLOAD DETECTION AND TIMING ($6 \leq V_D \leq 18 \text{ V}$; $-40^\circ\text{C} \leq T_J \leq 150^\circ\text{C}$ unless otherwise specified)

Symbol	Rating	Conditions	Min	Typ	Max	Unit
$V_D - V_{OL_OFF}$	Open Load Detection Threshold, OFF State	$V_{IN} = 0 \text{ V}$, $V_{CS_EN} = 5 \text{ V}$	1.3	1.8	2.3	V
t_{OSOL_Blank}	Open Load Detection Delay OFF State	$V_{IN} = 5 \text{ V} \rightarrow 0 \text{ V}$, $V_{CS_EN} = 5 \text{ V}$, $V_D = V_{OUT} = 13.5 \text{ V}$, $T_{CS} = 90\% I_{CS_FAULT}$, $R_{CS} = 1.2 \text{ k}\Omega$, $C_{CS} < 100 \text{ pF}$	30	70	120	μs
I_{OL_ON}	Open Load Detection Threshold, ON State	$V_{IN} = 5 \text{ V}$, $V_{CS_EN} = 5 \text{ V}$, $I_{CS} = I_{CS(OL)} = 4 \mu\text{A}$	6	-	32	mA

APPLICATION DIAGRAM AND PIN DESCRIPTION

NCV84003F is a single channel smart high-side driver with a very low resistance n-channel output transistor. The required gate overdrive voltage for the transistor is generated by a charge pump that is integrated into the device. The output driver’s protection scheme is designed to support linear resistive loads as well as loads with high inrush current, e.g. lighting bulbs. The embedded control and protection functions provide full protection to the device as well as full-featured load diagnostic for open load, underload and short circuit through a current sense output

that delivers a fraction of the load current in nominal operation multiplexed with a fixed current output in a fault state. An accurate slew rate control is provided to minimize conducted EMI in case of a constant PWM operation. The device features an ultra-low quiescent current in standby mode to address quiescent current requirements of modern ECU designs.

The device provides direct control input (IN) and a diagnostic enable input (CS_EN) to control the information to be provided at the current sense output.

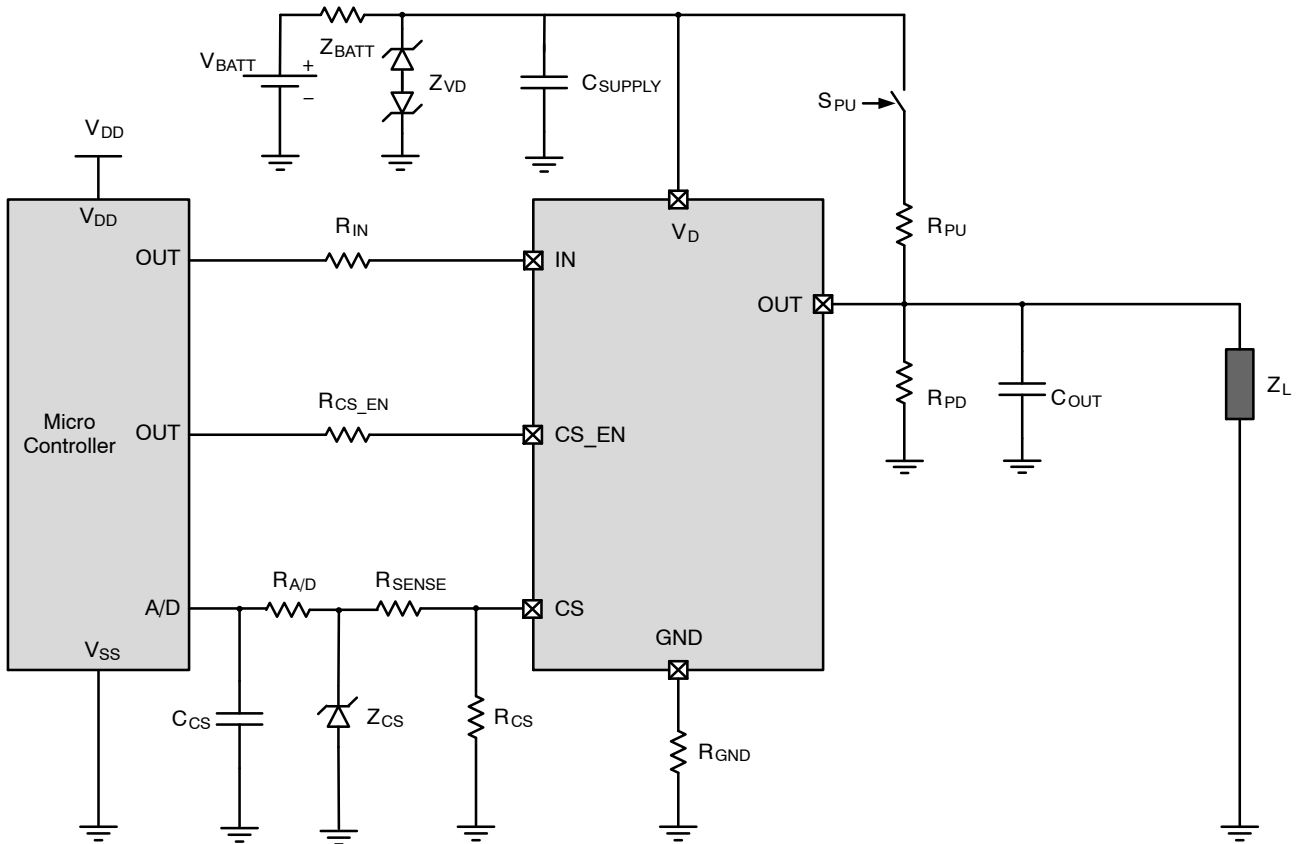

Figure 4. Application Diagram

NCV84003F is supplied by the V_D pin, which can be directly connected to the vehicle’s battery net. The V_D pin is used as power supply to the control circuitry as well as the common drain supply for output channels. In order to support all board net transients following ISO7637-1, an external protection concept as shown in Figure 4 is recommended.

The zener diode Z_{VD} is used to clamp overvoltage events as well as to provide a free-wheeling path in the event of loss of battery (V_D) with charged inductive loads. R_{GND} is required to limit the maximum current flowing through Z_{VD} (refer to Figure 14) in case of an over-voltage event. Since all low-voltage I/O pins feature input protection diodes, it is required to insert series resistances into the connection lines between the controlling device (e.g. microcontroller) and NCV84003F.

Table 12. RECOMMENDED EXTERNAL COMPONENTS

Reference	Value	Function
R _{IN}	4.7 kΩ	Provides protection of the micro controller during overvoltage and reverse polarity. Ensures the channel is OFF during loss of GND.
R _{CS_EN}	4.7 kΩ	Provides protection of the micro controller during overvoltage and reverse polarity. Ensures the channel is OFF during loss of GND.
R _{CS}	1.2 kΩ	Current Sense resistor.
R _{SENSE}	4.7 kΩ	Provides protection against overvoltage, reverse polarity, and loss of GND. The value of this resistor should be selected with the micro controller specification.
C _{SENSE}	100 pF	Current Sense signal filtering.
R _{A/D}	4.7 kΩ	Current Sense signal filtering.
Z _{CS} R _{PU}	10 V Zener Diode 1.5 kΩ	Provides protection micro controller during overvoltage at CS. Should be selected with the micro controller specification. Polarizes the NCV84003G output during OFF state open load diagnosis.
R _{PD}	47 kΩ	Output polarization. Improves the NCV84003G immunity to electromagnetic noise and also used for short to V _{BATT} detection.
S _{PU}	BC807	Switches the battery voltage for OFF state open load diagnostic.
R _{GND}	47 Ω	Provides protection during over-voltage.
Z _{VD}	30 V Zener Diode	Provides protection of the device during overvoltage.
C _{SUPPLY}	100 nF	Filtering of voltage spikes on the battery line.
C _{OUT}	4.7 nF	Protection during ESD and BCI on output.

MODES OF OPERATION

NCV84003F is designed to operate in the following distinct modes of operation as stated below. Irrespective of the modes below, it should be noted that if $V_D < V_{D(UV)}$, then the internal logic may be reset to default, and values of timers/counters cannot be guaranteed.

a. Sleep Mode

If IN and CS_EN have been observed as low for a duration longer than $t_{IN(Rst)}$ and, then the device enters sleep mode. The output FET is off. The internal reference blocks are shut down and digital logic is reset (as in case of supply-based reset) in this mode to offer extremely low quiescent current (Refer Table 3).

b. Standby Mode

If IN has been observed low for a duration more than $t_{IN(Rst)}$ and CS_EN is high then device operates in standby mode. The output FET is off. Off state diagnosis for open load and short circuit to V_{BATT} are available. If CS_EN continues to be high, device stays in standby mode.

c. Normal Mode

Once IN is set to High, the device transitions to normal mode. The turn on timing and slew in this mode are internally controlled and defined per Table 5. The device can be driven DC or in PWM operation while allowing for the switching delays. The CS pin outputs a current proportional to the load current if CS_EN is set to high. If diagnosis is desired, then CS response times per Table 10 need to be accounted for.

d. Protect Mode

While operating in normal mode, the device may observe either of the fault conditions described in [Protection Features](#), that trigger protect mode and lead to latching-off of the output stage. A fault current output on the CS pin will be provided if CS_EN is enabled. The reset conditions for the fault counter are described in section [ON State Fault Retry Strategy](#). If any of the reset conditions are met, device exits protect mode. ON state fault takes precedence over OSOL in off state if fault counter is greater than zero.

NCV84003F

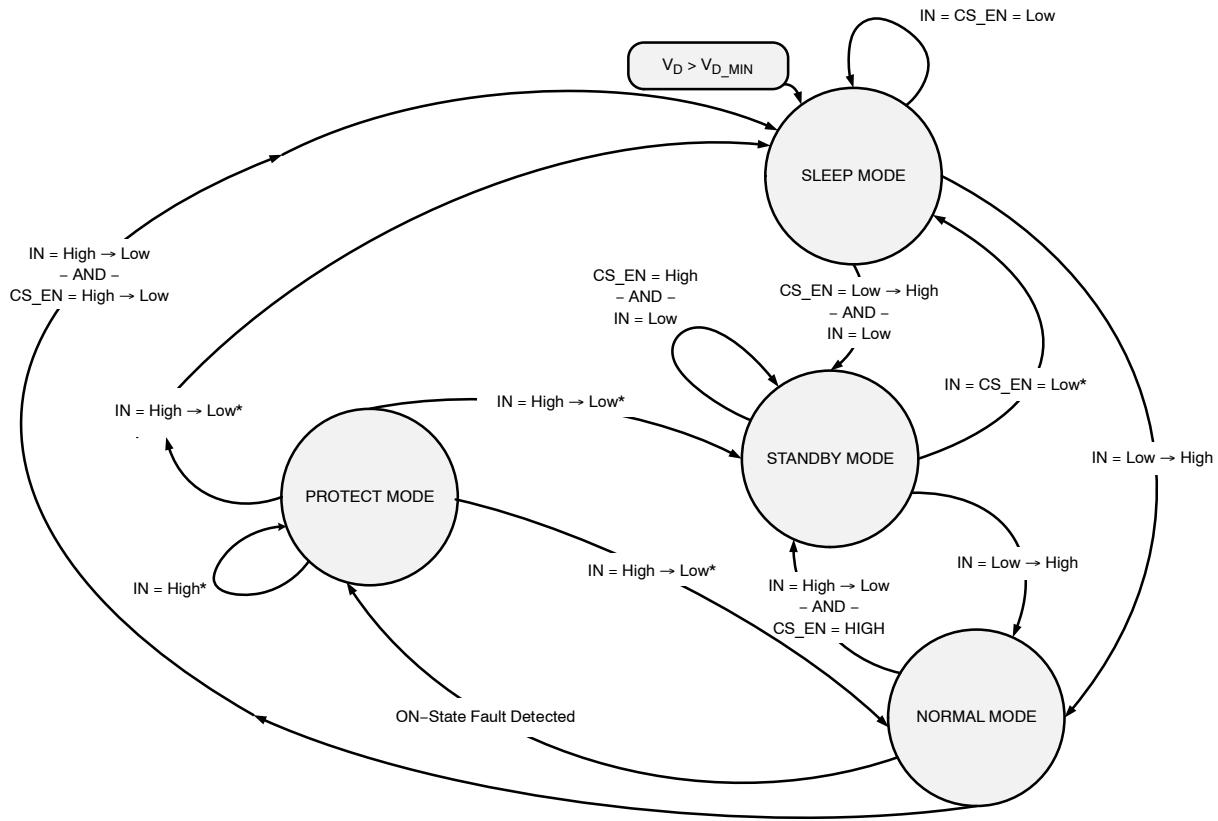

*see State Transition Table for transition qualifier

Figure 5. NCV84003F Operation Modes and Transitions

Table 13. STATE TRANSITION TABLE

Present State	Target State	Transition Criteria	Transition Qualifier
UNPOWERED	SLEEP MODE	$V_D > V_{D_MIN}$	
SLEEP MODE	STANDBY MODE	$CS_EN = Low \rightarrow High$ - AND - $IN = Low$	
SLEEP MODE	NORMAL MODE	$IN = Low \rightarrow High$	
NORMAL MODE	PROTECT MODE	ON-State Fault Detected	
NORMAL MODE	STANDBY MODE	$IN = High \rightarrow Low$	$t_{IN(Rst)}$ Expired
NORMAL MODE	SLEEP MODE	$IN = High \rightarrow Low$	$t_{IN(Rst)}$ Expired - AND - $CS_EN = Low$ over $t_{IN(Rst)}$
STANDBY MODE	NORMAL MODE	$IN = Low \rightarrow High$	
STANDBY MODE	SLEEP MODE	$IN = CS_EN = Low$	$t_{IN(Rst)}$ Expired
PROTECT MODE	STANDBY MODE	$IN = High \rightarrow Low$	$t_{IN(Rst)}$ Expired - AND - $CS_EN = High/CS_EN = Low$ for $t < t_{IN(Rst)}$
PROTECT MODE	SLEEP MODE	$IN = High \rightarrow Low$	$t_{IN(Rst)}$ Expired - AND - $CS_EN = Low$ over $t_{IN(Rst)}$
PROTECT MODE	NORMAL MODE	$IN = High \rightarrow Low$	$t_{IN(Rst)}$ Not Expired - AND - $t_{CS_EN(Rst)}$ Expired

NCV84003F

POWER STAGE

NCV84003F provides output power through an integrated N-channel vertical power MOSFET. The gate overdrive is provided by an integrated charge pump.

OUTPUT ON-STATE RESISTANCE

Like any MOSFET, the outputs ON-state resistance R_{ON} increases with the junction temperature T_J . R_{ON} also depends on the supply voltage V_D (Figure 6).

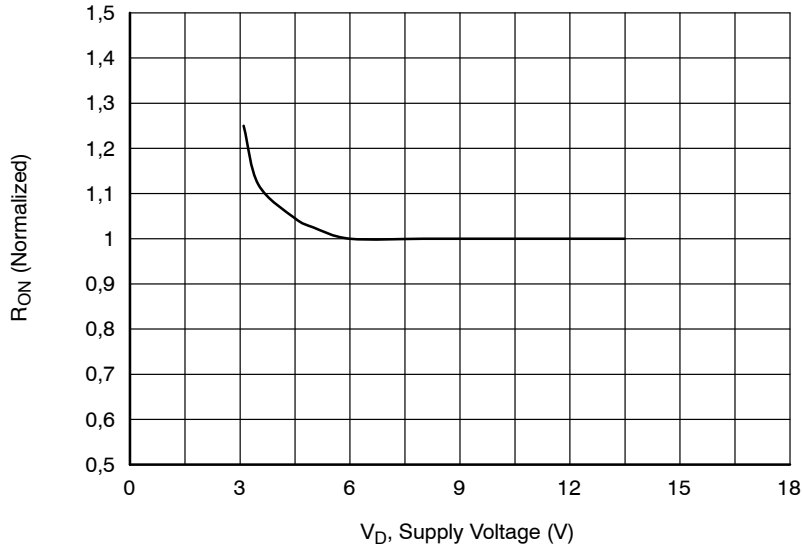

Figure 6. ON-state Resistance

Resistive Load Switching Characteristics

NCV84003F provides an integrated slow-rate control mechanism to minimize EMC in case of PWM operation.

The turn on delay time and the consequent turn on time while switching on the device from sleep mode is specified longer (refer to Table 5) to allow configuration of internal circuits.

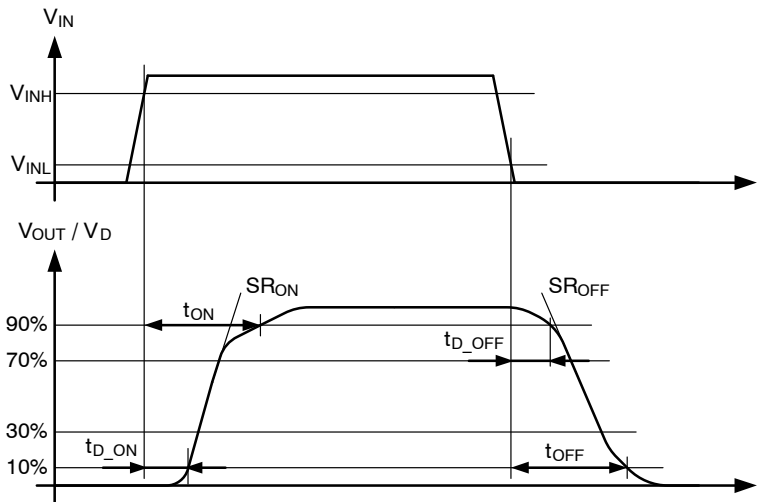

Figure 7. Resistive Load Switching Timing

Output Clamping with Inductive Load Switch Off

The output voltage V_{OUT} drops below GND potential when switching off inductive loads. This is because the inductance develops a negative voltage across the load in response to a decaying current. The integral clamp diode (Z_{CL}) clamps the negative output voltage to a certain level

relative to the supply voltage V_D . During output clamping with inductive load switch off, the energy stored in the inductance is rapidly dissipated in the device resulting in high power dissipation. This is a stressful condition for the device and the maximum energy allowed for a given load inductance should not be exceeded in any application.

NCV84003F

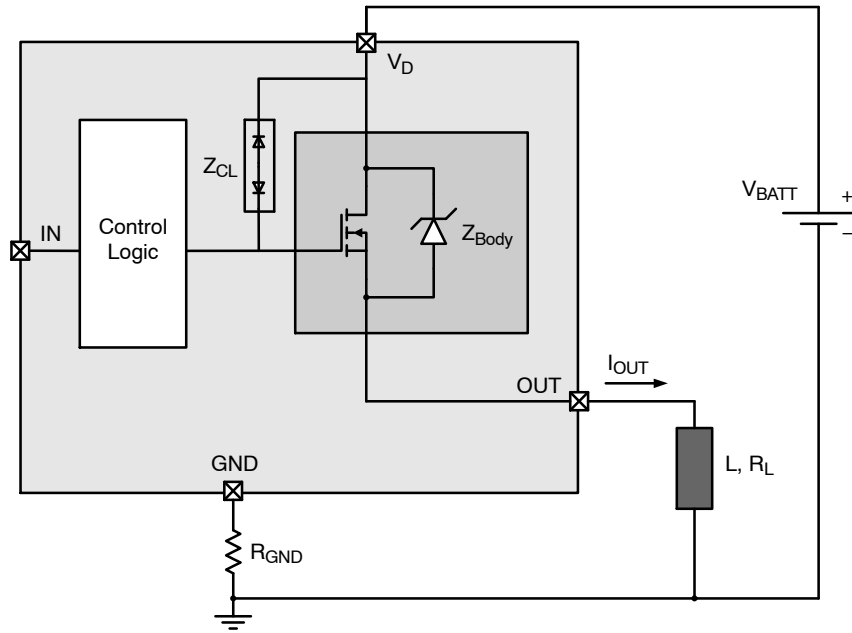

Figure 8. Output Clamping

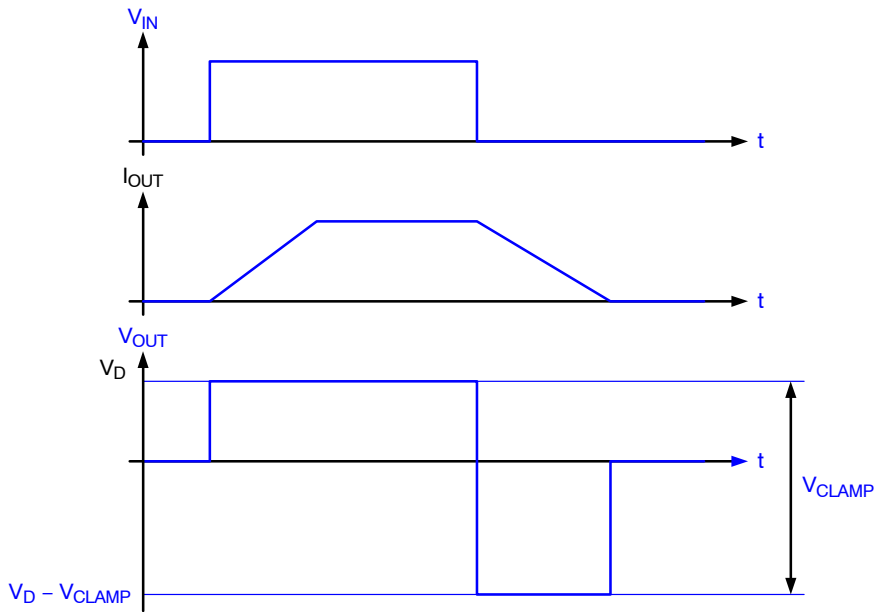

Figure 9. Inductive Load Switching Timing

The channel's energy capability [J] for inductive switching is given as follows, referring to Figure 8:

$$E = (V_D - V_{OUT}) \cdot \left[\frac{V_D - V_{OUT}}{R_L} \cdot \ln \left(1 - \frac{R_L \cdot I_{OUT}}{V_D - V_{OUT}} \right) + I_{OUT} \right] \cdot \frac{L}{R_L} \quad (\text{eq. 1})$$

PROTECTION FEATURES

In application, the device can be subject to stressful conditions which are outside of normal operating range. To prevent damage and destruction of the device from these fault conditions, several protection functions are integrated in device design. It is important to diagnose and remove any fault condition that may exist since the protection functions cannot prevent damage over sustained fault state operation.

Inverse Current

The protection logic in the device detects when the output voltage V_{OUT} rises above the supply voltage V_D and adjusts

the output stage to be turned on in an inverted configuration, thereby shunting the body diode and limiting the losses in case of an inverse current flow. The parameter R_{ON_INV} (Refer Table 3) specifies the resistance offered by the output stage in an inverted configuration. The current sense output stays low during inverse current conduction at the output stage. During Inverse Current operation, protection features as discussed in the ON-State Fault Retry Strategy section may not be available.

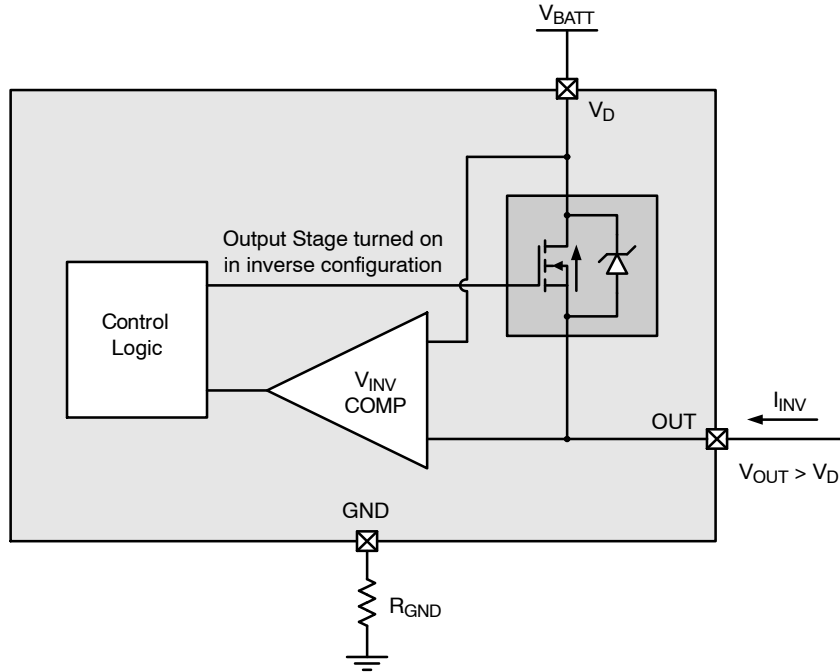

Figure 10. Inverse Current

LOSS OF GROUND PROTECTION

When device or ECU ground connection is lost and the load is still connected to ground, the device will turn the output OFF. In loss of ground state, the output stage is held OFF independent of the state of the input. Protection

mechanisms and current sense output of the device will not be available during loss of device ground. Series resistors are recommended between the device and microcontroller to prevent the I/O pins from providing a parasitic GND path through microcontroller.

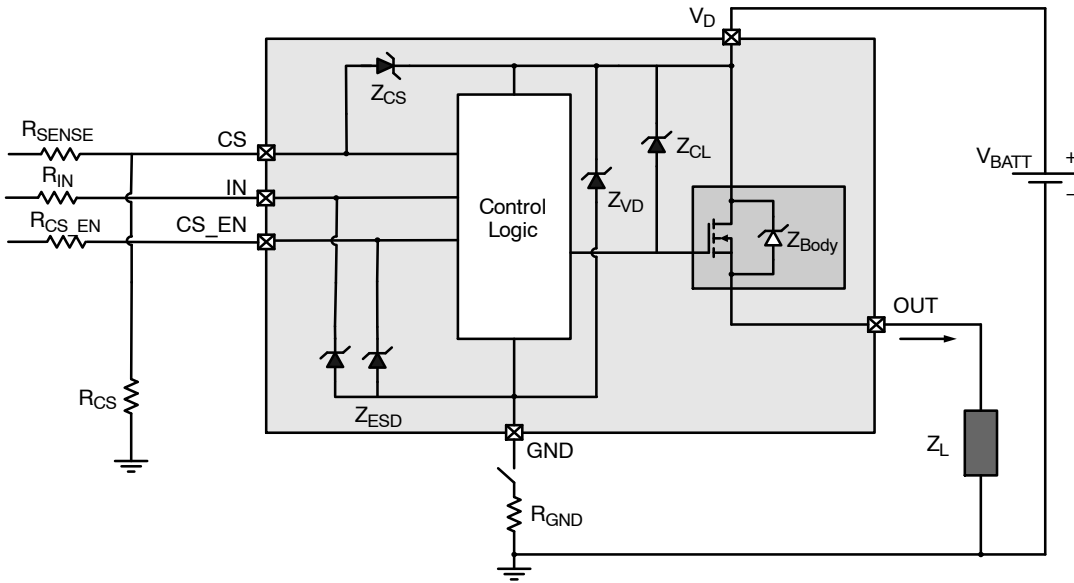

Figure 11. Loss of Ground Protection

UNDERVOLTAGE PROTECTION

The device has two under voltage threshold levels, V_{D_MIN} and V_{D_UV} . Switching function (ON/OFF) requires supply voltage to be at least V_{D_MIN} . The device features a lower supply threshold V_{D_UV} , above which the output can

remain in ON state, if already ON. The protection and diagnostic features are available and functional down to V_{D_UV} (if switch already ON), however, may deviate from the nominally specified parametric performance.

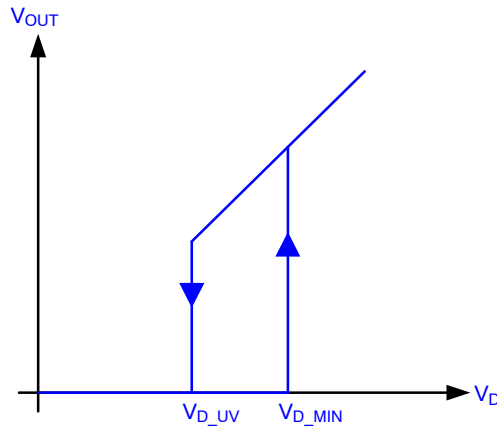

Figure 12. Under-voltage Behavior

In case the supply voltage drops below V_{D_UV} while the channel is ON ($V_{IN} = \text{High}$), the output stage shuts off and a delay time $t_{UV_Recover}$ is incorporated before turning on the output again once the supply increases more than V_{D_MIN} . Such a protection scheme precludes fast repetitive turn on and turn off events and reduces the transient stress on the device as the supply periodically increases or

decreases around the under-voltage threshold while conducting high currents. Once initiated, this delay timer is independent of the transitions at the IN pin as shown in Figure 13 below. The delay $t_{UV_Recover}$ is not present if the power supply voltage is greater than V_{D_MIN} at the time of turning the channel ON ($V_{IN}: \text{Low} \rightarrow \text{High}$).

NCV84003F

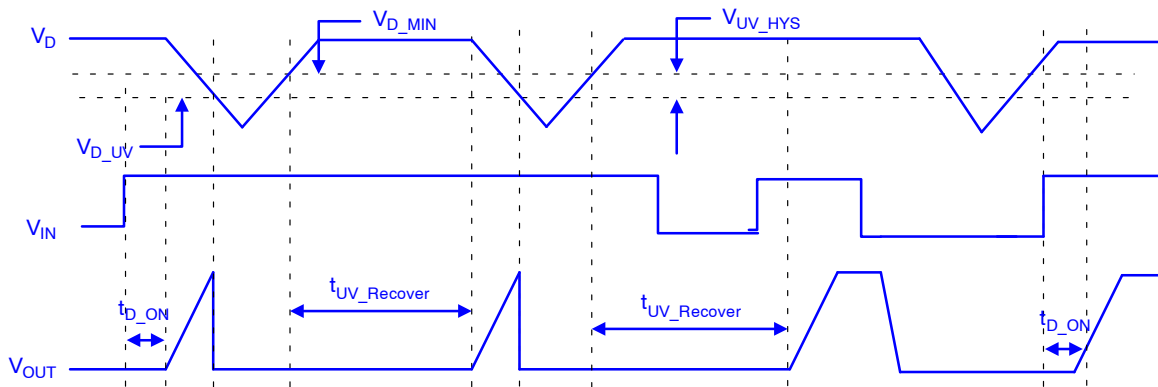

Figure 13. Under-voltage Recovery Timing

Overvoltage Protection

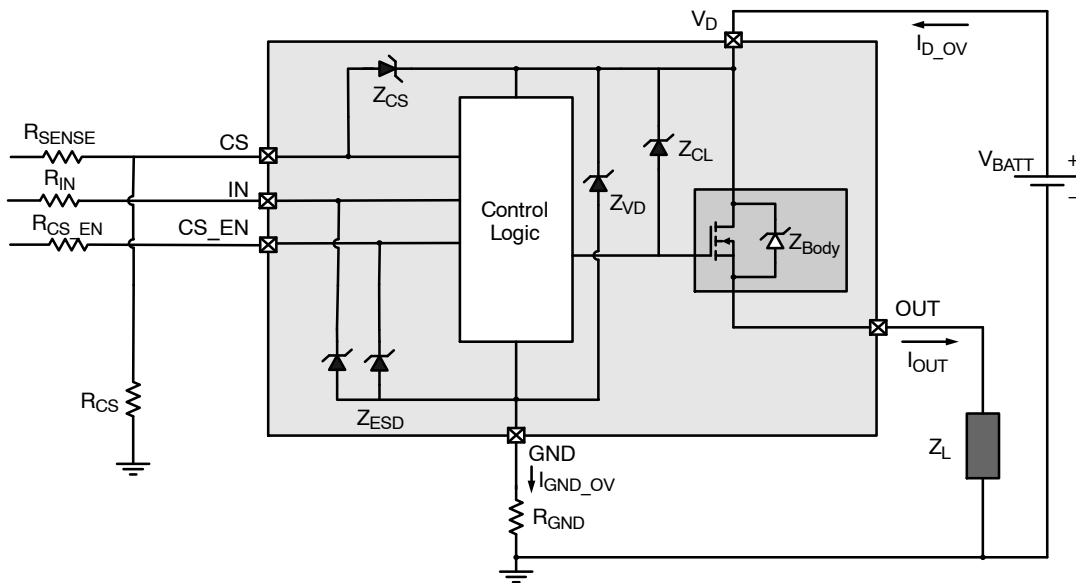

Figure 14. Overvoltage Protection Circuit

The NCV84003F employs a set of over-voltage protection zener clamp diodes – Z_{VD} , Z_{CL} , Z_{ESD} and Z_{CS} , which protect the device against abnormal high voltage events. Z_{VD} protects the logic part by clamping the voltage between supply pin V_D and ground pin GND to V_{ZVD} . Z_{CS} limits voltage at current sense pin IS to $V_D - V_{ZCS}$. The output power MOSFET's integral body diode Z_{CL} provides protection by clamping the voltage across the MOSFET (between V_D pin and OUT pin) to $\sim V_{ZCL}$. During overvoltage protection, current flowing through Z_{VD} , Z_{CS} and Z_{CL} must be limited. Load impedance Z_L limits the current in output clamp. In order to limit the current in Z_{VD} , a resistor, R_{GND} , is required in the GND path. External resistors R_{CS} and R_{SENSE} limit the current flowing through

Z_{IS} and out of the IS pin into the micro-controller I/O pin. With R_{GND} , GND pin voltage is elevated to $V_D - V_{ZVD}$ when the drain potential V_D rises above V_{ZVD} . ESD diodes Z_{ESD} clamp the voltage at logic pins IN and CS_EN close to the GND pin voltage $V_D - V_{ZVD}$. External resistors R_{IN} and R_{CS_EN} are required to limit the current flowing out of the logic pins into the micro-controller I/O pins. During overvoltage exposure, the device transitions into a self-protection state, with automatic recovery after the supply voltage comes back to the normal operating range. The parametric spec, diagnostic capability as well as short circuit robustness and energy capability cannot be guaranteed during overvoltage exposure.

REVERSE BATTERY PROTECTION

In case of Reverse Battery connection, the external load limits the current through the body diode of the output FET. An integrated blocking mechanism blocks the reverse current flowing into the GND and reduces the constraints on the value of R_{GND} . The diagnostic output stays OFF in a reverse battery configuration and no protection feature such as current limitation or over-temperature shutdown is

available. A typical application setup for reverse battery protection is shown in Figure 15. The current in the logic pins' ESD protection diodes is limited by resistors R_{IN} and R_{CS_EN} . Resistors R_{CS} and R_{SENSE} limit the current flowing in the CS pin. The resistor values have to be chosen to limit the current within the current ratings specified in the absolute maximum rating section.

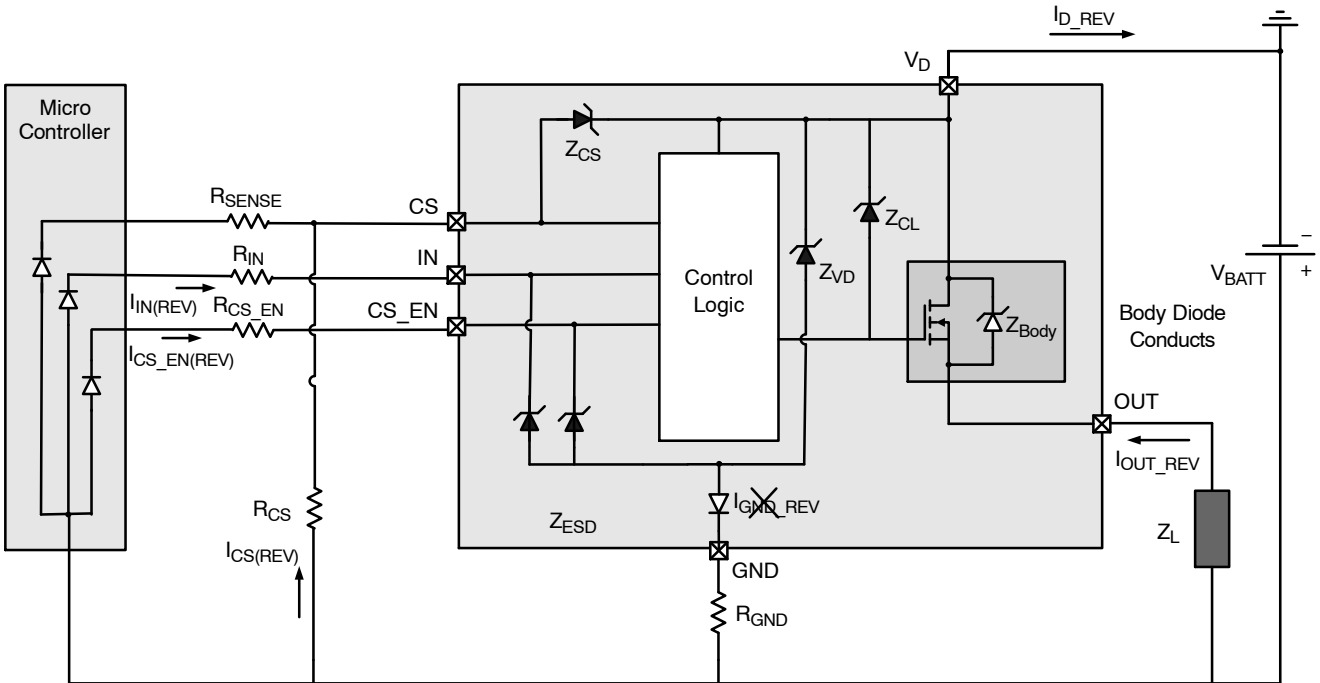

Figure 15. Reverse Battery Protection Circuit

OVERLOAD PROTECTION

Over-current detection as well as over temperature shutdown mechanisms is integrated into NCV84003F to

provide protection from overload conditions such as bulb inrush or output short to ground.

OVER-CURRENT SHUTDOWN

In case of overload, NCV84003F limits the current in the output power MOSFET to a safe value (Refer Table 6). The device is immediately turned off once a peak current equal to I_{LIM} is detected thereby preventing any further power dissipation. To ensure the inrush requirements of bulb/capacitive loads, a re-try strategy is defined in the section [On-State Fault Retry Strategy](#).

The over-current detection threshold of the device is reduced to a lower value in case of high drain-source voltage. This is done to limit the amount of power dissipation and consequential thermal transients. The curve below depicts the trend in normalized I_{LIM} where the value “1” represents the peak measured at $V_{DS} = 5\text{ V}$.

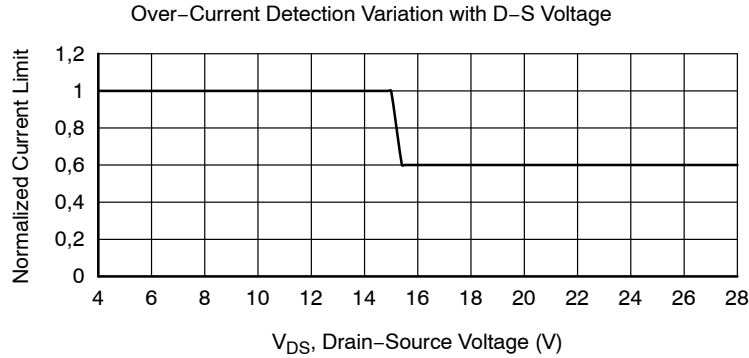

Figure 16. Over-Current Detection Variation with Drain-Source Voltage

A similar protection logic is applied at high Drain voltages, specifically for conditions such as Jump Start

(Refer Table 6). In addition, the current limit also observes a negative coefficient of variation with temperature.

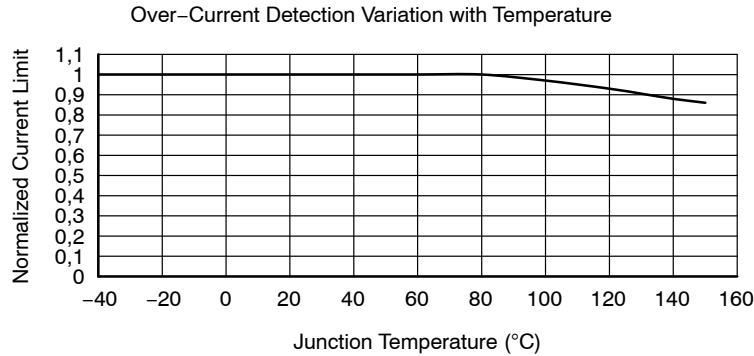

Figure 17. Over-Current Detection Variation with Junction Temperature

OVER TEMPERATURE PROTECTION

NCV84003F has two over temperature shutdown mechanisms. They are implemented by incorporating an absolute and a differential temperature sensor. To prevent damage and/or destruction, when either of the two sensors is activated, the output will be switched OFF. In case of a prolonged high power dissipation condition, a rapid increase in the junction temperature creates a severe temperature gradient within the device. When this differential

temperature swing reaches the defined threshold (T_{DTSD} , per Table 6), the differential temperature sensor is activated thereby switching OFF the device. In case if the junction temperature reaches thermal shutdown temperature T_{TSD} , the absolute temperature sensor is activated, and the output stage will be switched OFF. The output will be allowed to turn back ON when the differential temperature drops to a safe value determined by the hysteresis T_{TSD_HYS} (Refer Table 6) with a retry strategy presented in the next section.

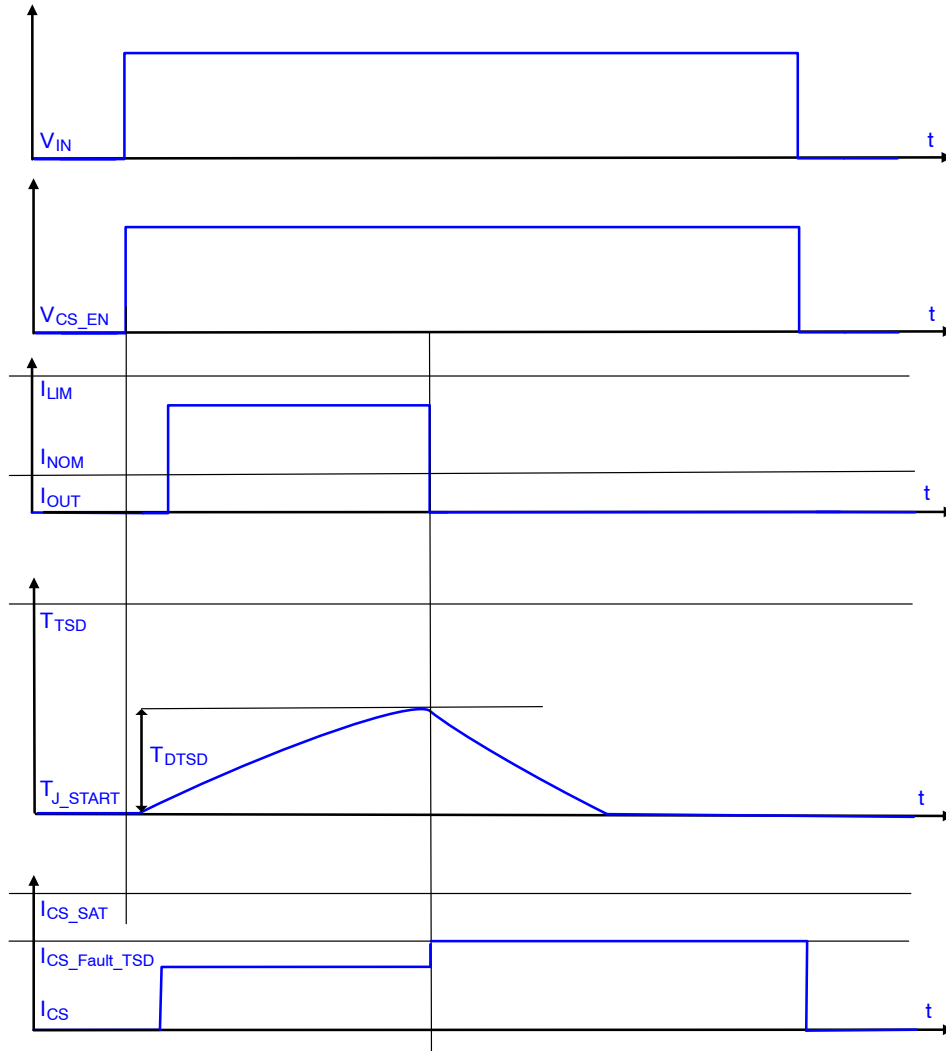

Figure 18. Over-Temperature Protection

ON STATE FAULT RETRY STRATEGY

The timing diagram below explains the re-try strategy in case of a current limit and/or over-temperature fault state. It should be noted that while the particular example below considers a short circuit to GND, or a current limit condition, the same philosophy can be applied to re-tries in case of an over-temperature event.

When exposed to the fault conditions mentioned above, the output stage is latched off after incrementing the fault counter once to protect the device from subsequent high

power re-try pulses. The fault counter can be reset to zero (default) by forcing IN low for a time period $t > t_{IN(Rst)}$, or by forcing a diagnostic enable pulse while IN = low as shown above. If the IN pin is switched Low \rightarrow High before the $t_{IN(Rst)}$ timer expires, then the output stage stays off. The timer is reset and starts over again when the input goes low the next time. A current sense enable based reset provides a faster solution to reset the counter (typically used in cases where the application microcontroller detects a normal operating condition, and a quick re-start is desired).

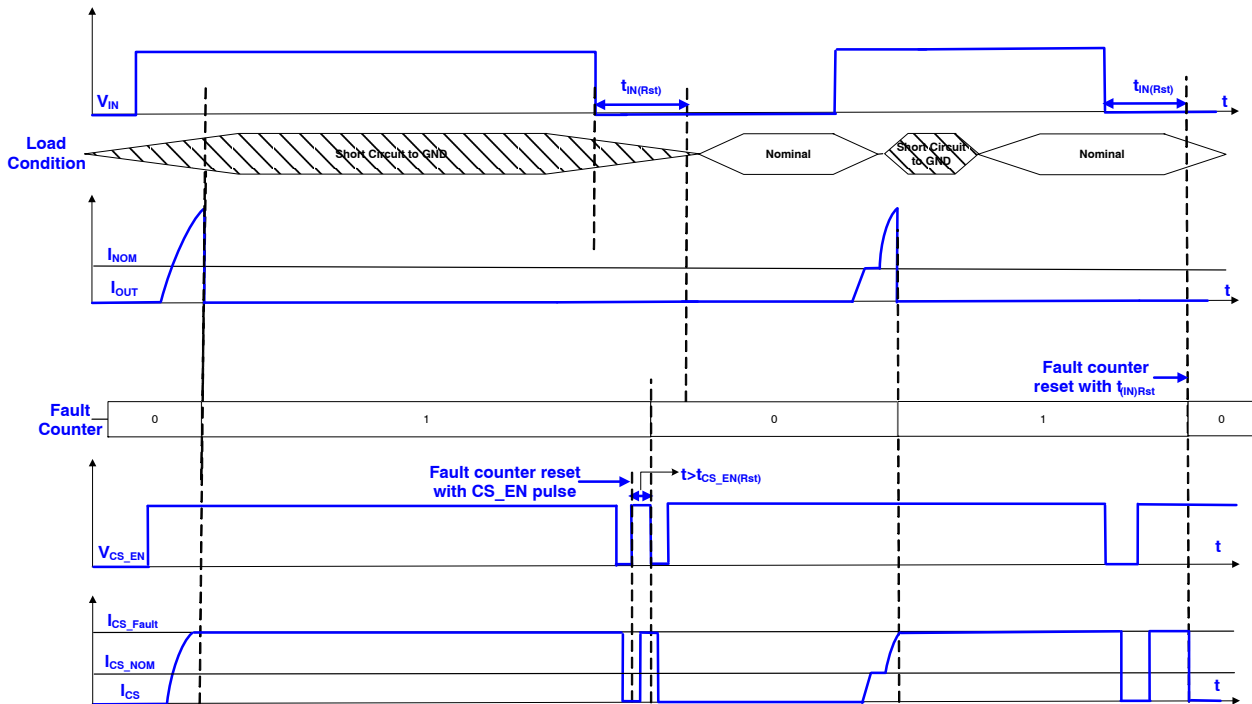

Figure 19. Retry Strategy in Case of Current Limit and/or Over-Temperature

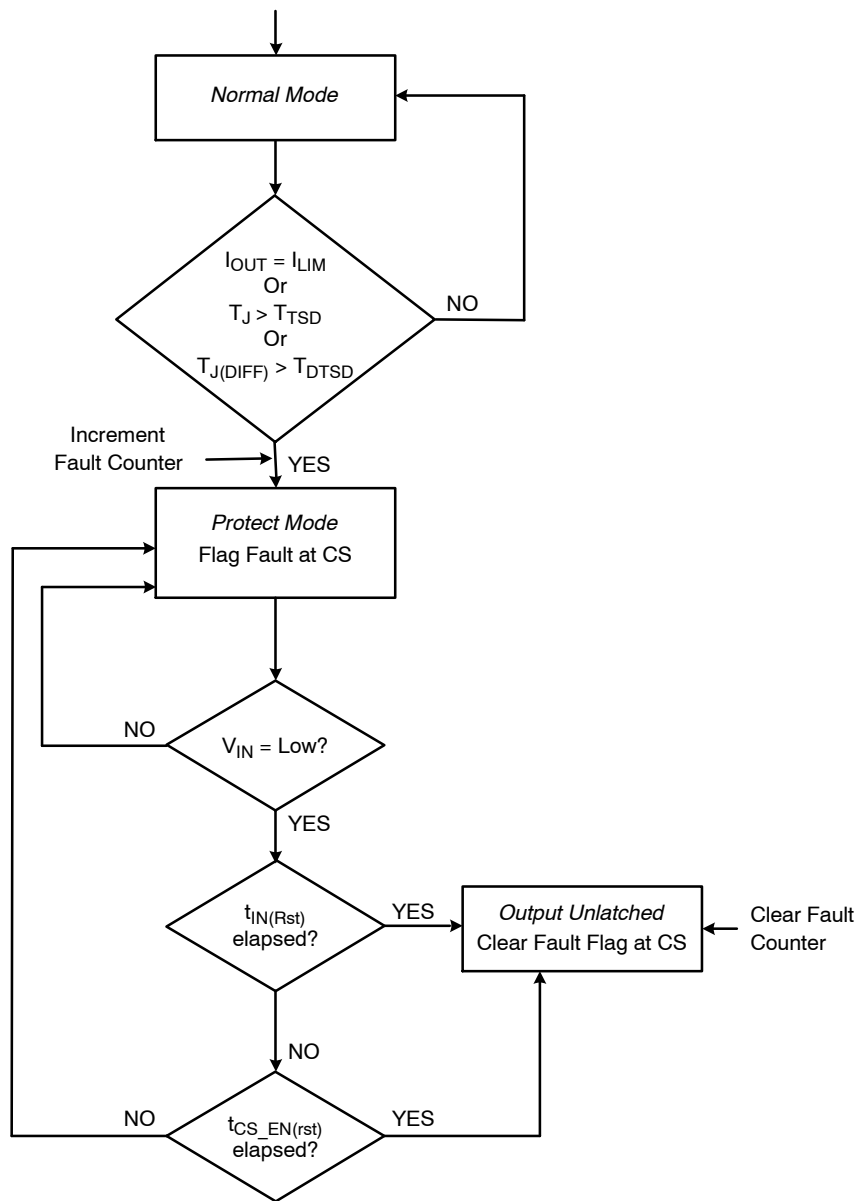

Figure 20. On-State Re-try Strategy Flowchart

CURRENT SENSE OUTPUT TIMING

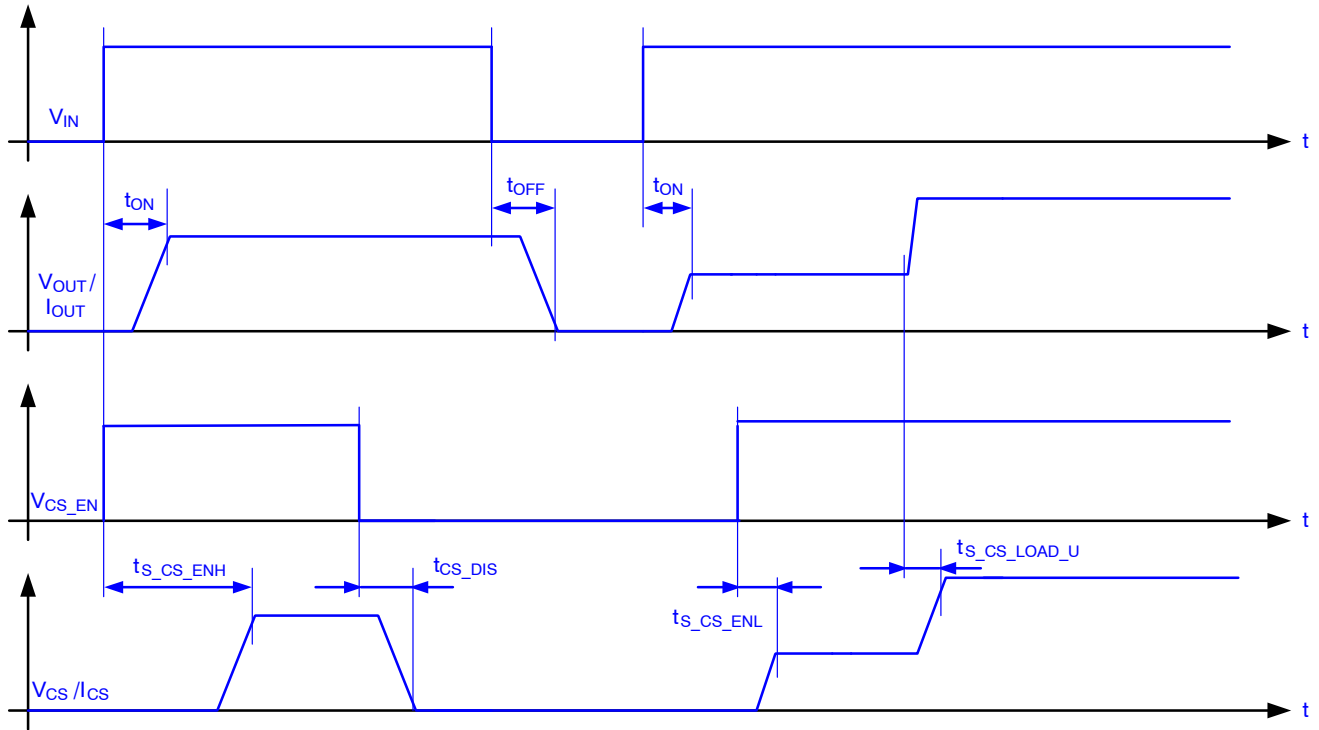

Figure 21. Current Sense Timings

OPEN LOAD/SHORT TO V_{BATT} DETECTION IN OFF STATE

Open load diagnosis in OFF state can be performed by activating an external resistive pull-up path (R_{PU}) to V_{BATT} . To calculate the pull-up resistance, external leakage currents (designed pull-down resistance, humidity-induced leakage etc) as well as the open load threshold voltage V_{OL_OFF} have to be taken into account. A switch can be used open the battery connection to R_{PU} to prevent undesired

leakage through this path in case an open load diagnostics is not required.

A short circuit to V_{BATT} in off state is also detected by the same analog circuit block.

It should be noted that OSOL Fault current range is exclusive to and lower than other fault conditions such as a TSD or a current limit. This segregation of fault levels will help user to distinguish an OSOL fault from a case where a fault is being flagged high in OFF state due to an un-expired Fault counter (Refer to Table 8).

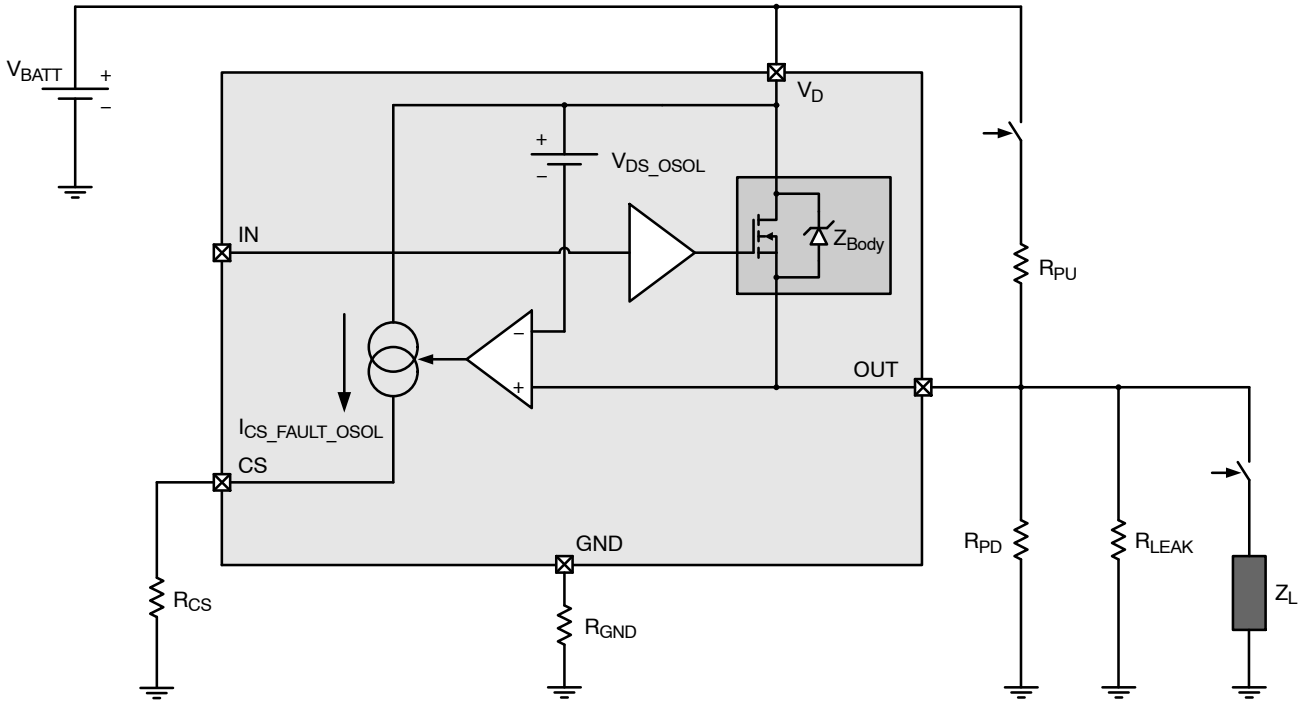

Figure 22. OFF State Open Load Detection Circuit

TBD

Figure 23. Transient Thermal Response

NCV84003F

PACKAGE DIMENSIONS

TSSOP14 EP
CASE 948BZ
ISSUE A

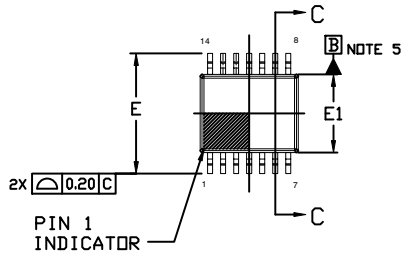

TOP VIEW

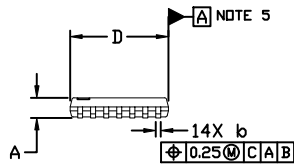

SIDE VIEW

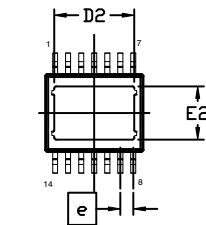
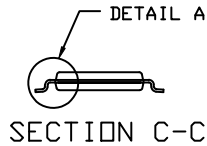

BOTTOM VIEW

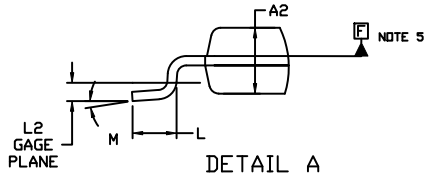

DETAIL A

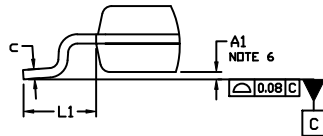

DETAIL A
(SUPPLEMENTAL)

NOTES:

1. DIMENSIONING AND TOLERANCING PER ASME Y14.5M, 2009.
2. CONTROLLING DIMENSION: MILLIMETERS
3. DIMENSION b DOES NOT INCLUDE DAMBAR PROTRUSION. ALLOWABLE PROTRUSION SHALL BE 0.127 mm IN EXCESS OF MAXIMUM MATERIAL CONDITION.
4. DIMENSIONS D AND E1 DO NOT INCLUDE MOLD FLASH, PROTRUSIONS, OR GATE BURRS. MOLD FLASH, PROTRUSIONS, OR GATE BURRS SHALL NOT EXCEED 0.25 mm PER SIDE. DIMENSIONS D AND E1 ARE DETERMINED AT DATUM F.
5. DATUMS A AND B ARE TO BE DETERMINED AT DATUM F.
6. A1 IS DEFINED AS THE VERTICAL DISTANCE FROM THE SEATING PLANE TO THE LOWEST POINT ON THE PACKAGE BODY.
7. LEAD THICKNESS (c) AND LEAD WIDTH (b) INCLUDE PLATING THICKNESS.

DIM	MILLIMETERS		
	MIN.	NOM.	MAX.
A	---	---	1.15
A1	0.00	---	0.10
A2	0.95 REF		
b	0.20	---	0.30
c	0.20 REF		
D	4.80	4.90	5.00
D2	3.90	4.00	4.10
E	5.80	6.00	6.20
E1	3.80	3.90	4.00
E2	2.55	2.65	2.75
e	0.65 BSC		
L	0.42	---	---
L1	1.05 REF		
L2	0.25 REF		
M	0°	---	8°

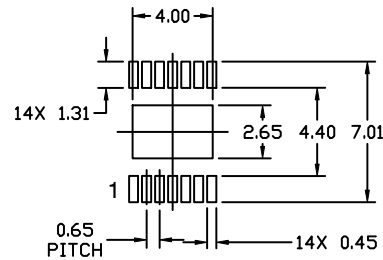

RECOMMENDED
MOUNTING FOOTPRINT

* For additional information on our Pb-Free strategy and soldering details, please download the ON Semiconductor Soldering and Mounting Techniques Reference Manual, SOLDERRM/D.

onsemi, **Onsemi**, and other names, marks, and brands are registered and/or common law trademarks of Semiconductor Components Industries, LLC dba "**onsemi**" or its affiliates and/or subsidiaries in the United States and/or other countries. **onsemi** owns the rights to a number of patents, trademarks, copyrights, trade secrets, and other intellectual property. A listing of **onsemi**'s product/patent coverage may be accessed at www.onsemi.com/site/pdf/Patent-Marking.pdf. **onsemi** reserves the right to make changes at any time to any products or information herein, without notice. The information herein is provided "as-is" and **onsemi** makes no warranty, representation or guarantee regarding the accuracy of the information, product features, availability, functionality, or suitability of its products for any particular purpose, nor does **onsemi** assume any liability arising out of the application or use of any product or circuit, and specifically disclaims any and all liability, including without limitation special, consequential or incidental damages. Buyer is responsible for its products and applications using **onsemi** products, including compliance with all laws, regulations and safety requirements or standards, regardless of any support or applications information provided by **onsemi**. "Typical" parameters which may be provided in **onsemi** data sheets and/or specifications can and do vary in different applications and actual performance may vary over time. All operating parameters, including "Typicals" must be validated for each customer application by customer's technical experts. **onsemi** does not convey any license under any of its intellectual property rights nor the rights of others. **onsemi** products are not designed, intended, or authorized for use as a critical component in life support systems or any FDA Class 3 medical devices or medical devices with a same or similar classification in a foreign jurisdiction or any devices intended for implantation in the human body. Should Buyer purchase or use **onsemi** products for any such unintended or unauthorized application, Buyer shall indemnify and hold **onsemi** and its officers, employees, subsidiaries, affiliates, and distributors harmless against all claims, costs, damages, and expenses, and reasonable attorney fees arising out of, directly or indirectly, any claim of personal injury or death associated with such unintended or unauthorized use, even if such claim alleges that **onsemi** was negligent regarding the design or manufacture of the part. **onsemi** is an Equal Opportunity/Affirmative Action Employer. This literature is subject to all applicable copyright laws and is not for resale in any manner.

ADDITIONAL INFORMATION

TECHNICAL PUBLICATIONS:

Technical Library: www.onsemi.com/design/resources/technical-documentation
onsemi Website: www.onsemi.com

ONLINE SUPPORT: www.onsemi.com/support

For additional information, please contact your local Sales Representative at www.onsemi.com/support/sales