



Typical Unit

## FEATURES

- Input Range of 36-75V, (48V nominal)
- Continuous Output of 28V @ 21.5A
- Adjustable Output Voltage: 14-35V
- Efficiency up to 96.5%
- 2,250Vdc Input/Output Isolation
- Industry Standard ¼ Brick Package
- Baseplate for Cooling Optimization
- Overcurrent & Overvoltage protection
- PMBus™ 1.2 Interface
- Black Box Stored Data
- Power-Good Signal
- Remote On/Off Control
- RoHS Compliant



For full details go to  
<https://www.murata-ps.com/rohs>



## SAFETY APPROVALS

- UL 62368-1 3<sup>rd</sup> Edition
- CSA C22.2 No. 62368-1-19
- IEC 62368-1:2018



## PRODUCT OVERVIEW

Murata Power Solutions is introducing a 600W, 28Vout, quarter brick module targeted for RFPA (Radio Frequency Power Amplifier) applications. The MPQ600-28V21-D48NBMC was designed to enable hardware engineers the flexibility to meet demanding RFPA system design goals. Features include a Vin range of 36-75Vdc, Vout trim range of 14V to 35V with module efficiency reaching 96.5% @ 48Vin full load. The module has an integrated baseplate that can be used to optimize the thermal performance in a closed box or air-cooled system application while providing Input-to-Output isolation of 2,250Vdc with a basic insulation system.

Standard features include Remote On/Off control, Remote Sense & Trim functions, Input Under Voltage, Over-current, Over Temperature and short circuit protection. Additionally, the MPQ600 module features a PMBus™ Interface that can be used to monitor input & output voltages, output current, and device temperature. The PMBus™ also allows users to configure many operational parameters including output voltage, current limit, Vout ramp rate, Vout delay and soft start/stop configuration for stable operation under a wide range of operating conditions.

The MPQ600 module is designed, tested and qualified according to the industry standard IPC9592 design for reliability requirements. Electrical performance is state-of-the-art starting with an efficiency rating of 96+% typical at full load, Pre-Bias protection under all conditions, tight line & load regulation, low output ripple & noise and fast load transient response.

## ORDERING GUIDE

Part Number <sup>1</sup>	V <sub>IN</sub>	V <sub>OUT</sub>	P <sub>OUT</sub>	L inch(mm)	W inch(mm)	H inch(mm)
MPQ600-28V21-D48NBC	36-75Vdc	28Vdc	600W	2.3 (58.42)	1.45 (36.83)	0.57 (14.4)
MPQ600-28V21-D48NBMC	36-75Vdc	28Vdc	600W	2.3 (58.42)	1.45 (36.83)	0.57 (14.4)

<sup>1</sup> Please see the Part Number Structure table on Page 2 for more information.

## INPUT VOLTAGE CHARACTERISTICS

Parameter	Conditions	Min.	Nom.	Max.	Units
Input Voltage, Operating		36	48	75	Vdc
Start-up Voltage		32	34	36	
Hysteresis		-	2	-	
Overvoltage Shutdown Recover		75	76	78	
Hysteresis		-	2	-	A
External Input Fuse		-	30	-	
Input Current	Vin @ 48V, Full Load	-	13	-	A <sup>2</sup> -Sec.
Low Line Input Current	Vin @ 36V	15	-	20	
Inrush Transient	Vin @ 48V	-	0.7	1	mA
No Load Input Current	Vin = 48V, Iout = 0, unit = ON	-	50	-	
Shut-Down Input Current	(Off, UV, OT)	-	10	-	

## OUTPUT VOLTAGE CHARACTERISTICS

Parameter	Conditions	Min.	Nom.	Max.	Units
Output Voltage Range	With external Trim adjustment	14.00	28.0	35.00	Vdc
Output Current		0	-	21.5	A
Output Power		0	-	600	W
Line Regulation		-1	-	1	%
Load Regulation		-1	-	1	
Ripple & Noise	20MHz Bandwidth	-	-	300	mVp-p
Output Capacitance	X-CON Electronics KEMET-A759	680	-	4500	µF

## GENERAL & SAFETY

Parameter	Conditions	Min.	Nom.	Max.	Units
Efficiency	Vin=48V, Pout=600W, Ta=25°C	-	96.5	-	%
Switching Frequency		100	-	240	kHz
Isolation Voltage	Input to Output Test Voltage	-	-	2250	Vdc
	Input to Baseplate Test Voltage	-	-	1500	
	Baseplate to Output Test Voltage	-	-	1500	

**PERFORMANCE SPECIFICATIONS SUMMARY AND ORDERING GUIDE [1]**

Model Number [2]	Output					Input			Efficiency	
	V <sub>out</sub> (V)	I <sub>OUT</sub> (A, max.)	Total Power (W)	Ripple & Noise (mVp-p, max.)	Regulation (max.)		V <sub>in</sub> Nom. (V)	Range (V)	I <sub>in</sub> , full load@V <sub>in</sub> Nom. (A)	Typ
					Line (%)	Load (%)				
MPQ600-28V21-D48NBC	28	21.5	600	300	1.0	1.0	48	36-75	13	96.5%
MPQ600-28V21-D48NBMC	28	21.5	600	300	1.0	1.0	48	36-75	13	96.5%

Notes:

[1] Typical at Ta = +25°C under nominal line voltage and full-load conditions.

All models are specified with an external 1µF multi-layer ceramic and 10µF capacitors across their output pins.

[2] Please see the Part Number Structure below for details.

**PART NUMBER STRUCTURE**

Product Family	M	P									MP = Murata Power
Form Factor			Q								Q = Quarter Brick (Industry Standard Pinout)
Output Power				600							600W
Output Voltage					28V						28V <sub>out</sub>
Output Current						21					Max I <sub>out</sub> in Amps
Input Voltage Range							D48				D48 = 36-75V <sub>in</sub>
On/Off Control Logic								N			N = Negative Logic, (Standard Configuration), P = Positive Logic, (Optional - Contact Factory)
Mechanical Configuration									B		B = Baseplate
PMBus option										M	M = PMBus interface & Power Good included, Blank = Without PMBus, No Power Good
RoHS											C = RoHS Compliant

## FUNCTIONAL SPECIFICATIONS

ABSOLUTE MAXIMUM RATINGS	Conditions [1]	Minimum	Typical/Nominal	Maximum	Units
Input Voltage, Continuous		0		75	Vdc
Input Voltage, Transient	100 ms max. duration			100	
Isolation Voltage	Input to output (Basic insulation)			2250	
On/Off Remote Control	Power on, referred to -Vin	0		13.5	
Output Power		0		600	W
Output Current (28Vout)	Current-limited, no damage, short-circuit protected	0		21.5	A
Storage Temperature Range	Vin = Zero (no power)	-55		125	°C
Absolute maximums are stress ratings. Exposure of devices to greater than any of these conditions may adversely affect long-term reliability. Proper operation under conditions other than those listed in the Performance/Functional Specifications Table is not implied nor recommended.					
General Conditions for Device under Test unless otherwise specified: Typical at ambient temperature +25°C, nominal line voltage and nominal load conditions.					
INPUT					
Operating voltage range		36	48	75	Vdc
Start-up threshold		32	34	36	
Turn-On/Turn-Off Hysteresis	For Vout Rising		2		
Overvoltage Shutdown Recover		75	76	78	
Turn-On/Turn-Off Hysteresis	For Vout Falling		2		
Internal Filter Type			Pi		
External Input fuse			30		A
Input Current					
Full Load Conditions	Vin = nominal		13		A
Low Line input current	Vin = minimum	15		20	
Inrush Transient	Vin = 48V		0.7	1	A <sup>2</sup> -Sec.
No Load input current	Vin = 48V, Iout = 0, unit = ON		50		mA
Shut-Down input current	(Off, UV, OT)		10		
GENERAL AND SAFETY					
Efficiency	Vin = 42V, Full Load		94.5		%
	Vin = 48V, Full Load		96.5		
	Vin = 60V, Full Load		96.5		
Switch Frequency		100		240	kHz
Turn-On Time					
Turn-On Delay-1	Defined as time between Vin reaching Turn-On voltage and Vout reaching 10% of final value. Enable is asserted before Vin reaches Turn-On voltage	30		80	ms
Turn-On Delay-2	Defined as time between Enable and Vout reaching 10% of final value.	0		20	
Output Voltage Rise time	Defined as time between Vout at 10% of final value and Vout at 90% of final value.	30	60	100	
Isolation					
Test Voltage	Input to Output			2250	Vdc
	Input to Baseplate			1500	
	Output to Baseplate			1500	
Insulation Safety Rating			Basic		
Resistance			10		MΩ
Capacitance			1500		pF
Safety	Certified to UL62368-1:2019, CAN/CSA-C22.2 No. 62368-1-19, 3rd Ed, 2014-12-01; IEC62368-1:2018 (Third Edition)		Approved		
Calculated MTBF	Per Telcordia SR-332, Issue 3, Method 1, Case 1, Ground Fixed		5000		Hours x 10 <sup>3</sup>
DYNAMIC CHARACTERISTICS					
Dynamic Load Response	1. Load step = 25% of Pout Max from 50-75-50%. 2. External capacitance tested with a 1.0 μF ceramic, 10 μF tantalum and 680 μF low ESR polymer capacitor across the load.	0		900	μSec
Dynamic Load Peak Deviation	3. Low ESR polymer capacitor is X-CON Electronics A759PY687M1H(1)E026 or equivalent.	-1500		1500	mV
Pre-Bias Voltage		0		Vout	Vdc

FEATURES AND OPTIONS	Conditions	Minimum	Typical/Nominal	Maximum	Units
<b>Primary On/Off Control (suitable for driving open collector logic; voltages referenced to -Vin)</b>					
<b>"N" Suffix: (Standard Configuration)</b>					
Negative Logic, ON state	ON = ground pin or external voltage	-0.1		0.8	Vdc
Negative Logic, OFF state	OFF = pin open or external voltage	3.5		13.5	
Control Current	open collector/drain		0.1	0.2	mA
<b>"P" Suffix: (Optional – Contact Factory)</b>					
Positive Logic, ON state	ON = pin open or external voltage	3.5		13.5	Vdc
Positive Logic, OFF state	OFF = ground pin or external voltage	-0.1		0.8	
Control Current	open collector/drain		0.1	0.2	mA
Remote Sense Compliance	Sense pins connected externally to respective Vout pins			10	%
<b>Power-Good Signal</b>					
Output Voltage Low (trigger limits)			12.5		Vdc
Output Voltage High (trigger limits)			13.5		
Output Voltage Hysteresis		0.2			
High State Voltage		3		5.5	
High State Leakage Current (into Pin)		0		10	μA
Low State Voltage		0		0.8	V
Low State Current (into Pin)		0		5	mA
Power Good Signal De-assert Response Time		0		3	ms
Power Good Signal Assert Response Time		0		3	
<b>OUTPUT</b>					
Total Output Power		0		600	W
<b>Voltage</b>					
Initial Output Voltage	VIN = 48 V, Iout = 0 A, temp = 25 °C	27.90		28.10	Vdc
Output Adjust Range		14		35	
Trim Down: Trim (pin #J6) to -Vout Sense (pin #J5)	$Rt\ down\ (k\Omega) = 1 / ((V_{nom} - V_o) / V_{nom}) - 2$	-50			%
Trim Up: Trim (pin #J6) to +Vout Sense (pin #J7)	$Rt\ up\ (k\Omega) = 1 * V_{nom} * (1 + \Delta) / (1.225 * \Delta) - 1 / \Delta - 2$ $\Delta = (V_{nom} - V_o) / V_{nom}$			35	
<b>Current</b>					
Output Current Range		0		21.5	A
Minimum Load			No minimum load		
<b>Short Circuit</b>					
(remove short for recovery)					
Short circuit protection method			Latch		
<b>Regulation</b>					
Line Regulation	Vin = 36-75, Vout = nom., full load	-280		280	mV
Load Regulation	"Iout = min. to max., Vin = nom.  Vout@min_load - Vout@max_load  "	-280		280	
Ripple and Noise	1. Vin = Vin_min. to Vin_max and Io = Io_min to Io_max 2. Tested with a 1.0 μF ceramic, 10 μF tantalum between the test point and set typical 680 μF low ESR polymer capacitor near the Vout +/- PIN. 3. 680 μF low ESR polymer capacitor is X-CON Electronics A759PY687M1H(1)E026 or equivalent.	0		300	mV pk-pk
Recommended Capacitive Load	Recommendation is X-CON Electronics KEMET-A759 or equivalent.	680		4,500	μF
Temperature Coefficient			0.01	0.02	% of Vnom./°C
<b>Protection</b>					
Vout Undervoltage Shutdown		30	32	34	Vdc
Vin Overvoltage Shutdown		76	77.5	80	
Vout Overvoltage Shutdown			38		
Output Over-Current		23.5	26	28.5	A
Over-Temperature	baseplate hotspot		115		°C
<b>PMBus CALIBRATION ACCURACY</b>					
VIN_CALIBRATION		-6		6	%
VOUT_CALIBRATION		-2		2	
IOUT_CALIBRATION	0~50% Iout	-3		3	A
IOUT_CALIBRATION	50%~100% Iout	-5		5	%

MECHANICAL					
	Conditions	Minimum	Typical/Nominal	Maximum	Units
Outline Dimensions			2.3 x 1.45 x 0.57		Inches
			58.4 x 36.80 x 14.40		mm
Weight			2.35		Ounces
			80		Grams
Through Hole Pin Diameter			0.04 & 0.062		Inches
			1.016 & 1.575		mm
Digital Interface Pin Diameter			0.02		Inches
			0.5		mm
Through Hole Pin Material			Copper alloy		
TH Pin Plating Metal and Thickness	Nickel subplate		98.4-299		μ-inches
	Gold overplate		4.7-19.6		
ENVIRONMENTAL					
Operating Ambient Temperature Range	with derating	-40		85	°C
Storage Temperature	Vin = Zero (no power)	-55		125	
Altitude, Operating		-500		13120	feet
Relative Humidity	Operating, Non-Condensing	10		90	%
	Non-Operating, Non-Condensing	10		95	
Electromagnetic Interference Conducted, (FCC part 15, EN55022)	External filter required; see emissions performance test.		B		Class

**PERFORMANCE DATA**

**Start-up Voltage (48Vin)**

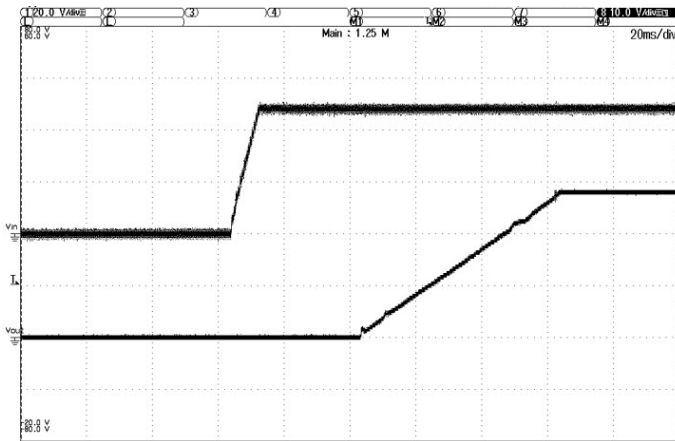

Start-up enabled by connecting VI at:  
TP1 = +25°C  
VI = 48 V  
IO = 21.5 A resistive load

Top trace: Input voltage (20 V/div.)  
Bottom trace: Output voltage (10 V/div.)  
Time scale: (20 ms/div.)

**Shut-down Voltage (48Vin)**

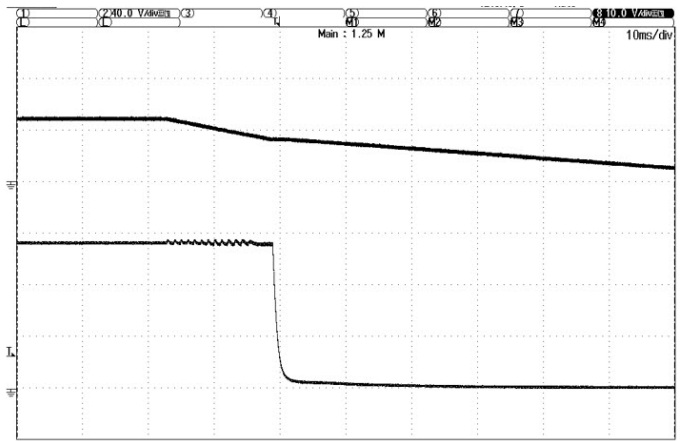

Shut-down enabled by disconnecting VI at:  
TP1 = +25°C  
VI = 48 V  
IO = 21.5 A resistive load

Top trace: Input voltage (40 V/div.)  
Bottom trace: Output voltage (10 V/div.)  
Time scale: (10 ms/div.)

**Output Ripple & Noise (48Vin)**

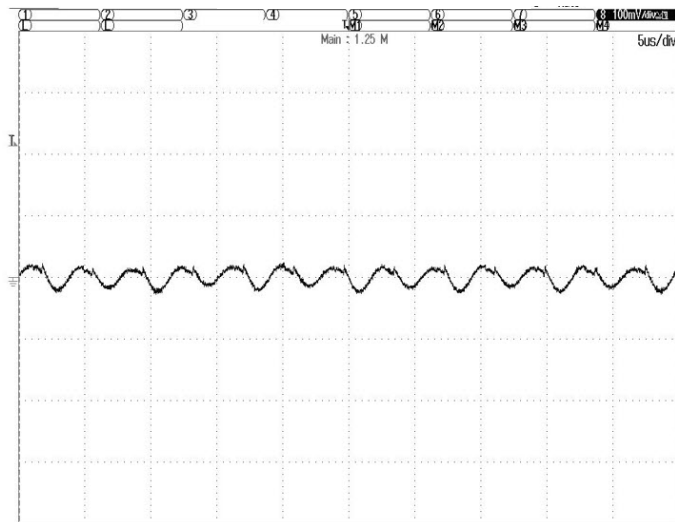

TP1 = +25°C  
VI = 48 V  
IO = 21.5 A resistive load

Trace: Output voltage (100 mV/div.)  
Time scale: (5µs/div.)  
20 MHz bandwidth filter 10 µF+1 µF

**Load Transient Waveform (1A/uS, 48Vin)**

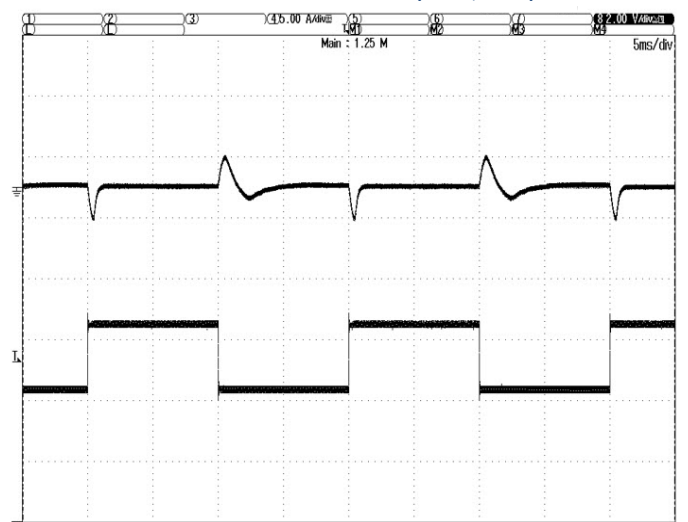

Output voltage response to load current  
step change (10.7A – 16.1A – 10.7A)  
TP1 = +25°C, VI = 48 V

Top trace: Output voltage (2V/div.)  
Bottom trace: Output current (5 A/div.)  
Time scale: (5 ms/div.)

**PERFORMANCE DATA**

**Output Power vs. Temperature**

Temperature Derating in Longitudinal Direction  
Vin=48Vdc (air flow direction is from Vin to Vout on 10x10 inch PCB)

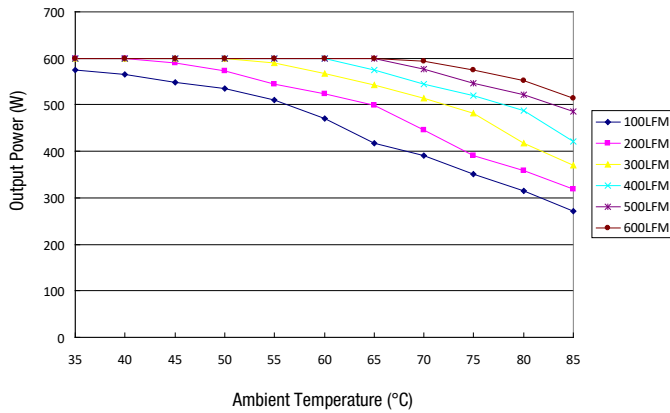

**Output Load Current vs. Temperature**

Temperature Derating in Longitudinal Direction  
Vin=48Vdc (air flow direction is from Vin to Vout on 10x10 inch PCB)

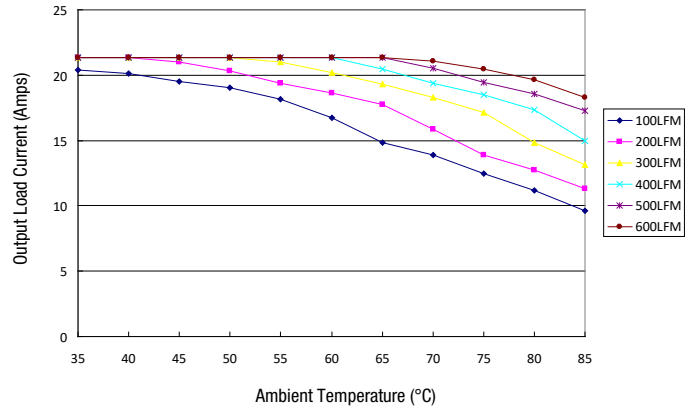

**Efficiency vs. Load Current & Input Voltage @ 25°C**

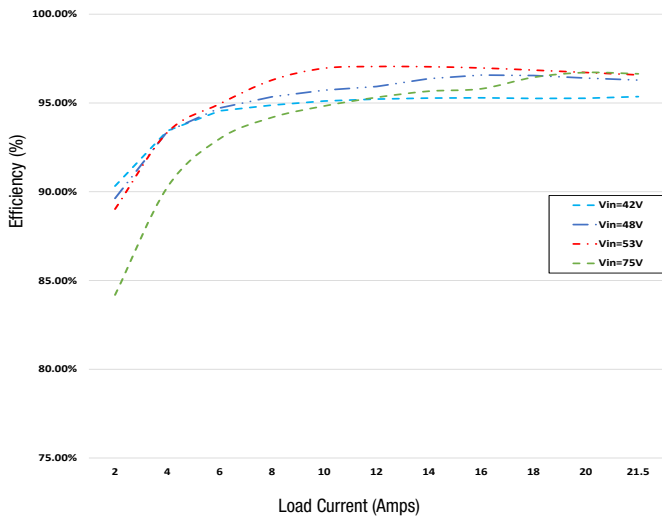

**Dissipated Power vs. Load Current & Input Voltage @ 25°C**

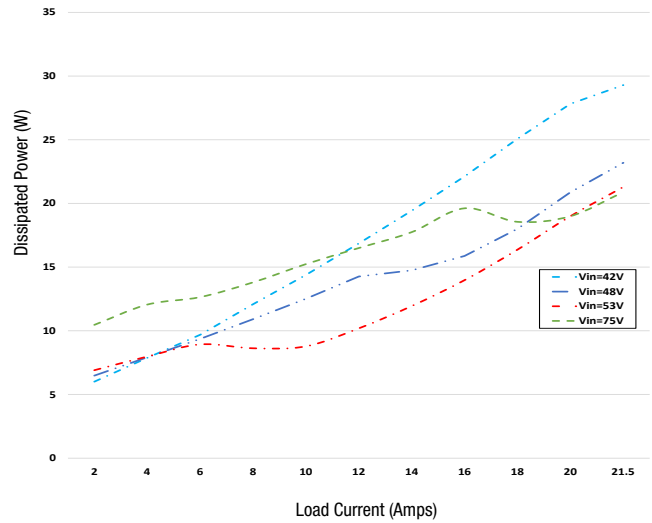

**PERFORMANCE DATA**

**Current Limit Characteristics @ 25°C**

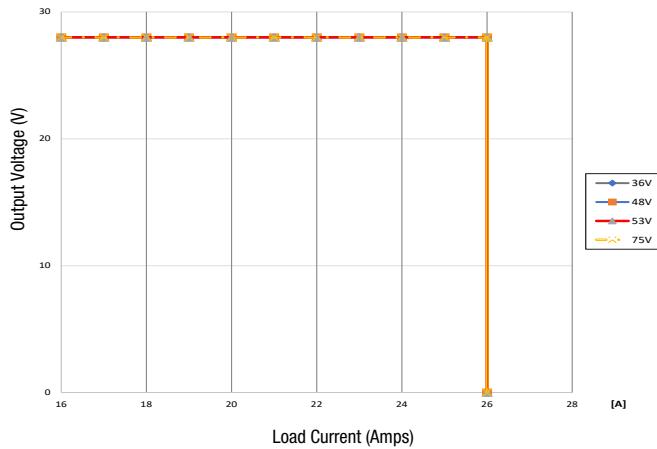

**Output Voltage vs. Load Current @ 25°C**

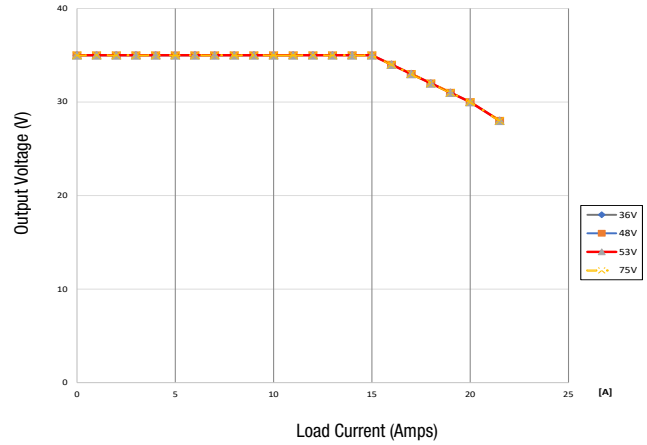

**Cold Wall Testing**

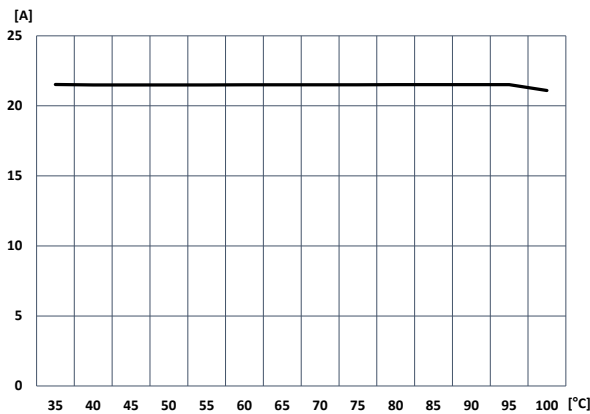

Available Load Current vs Baseplate Temperature  
VI = 48 V. See Thermal Consideration section.

**Cold Wall Test Set-up**

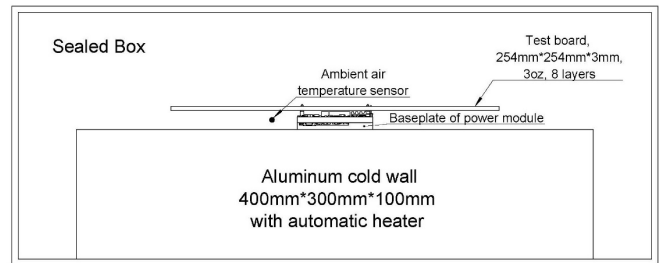

**Wind Tunnel Test Set-up**

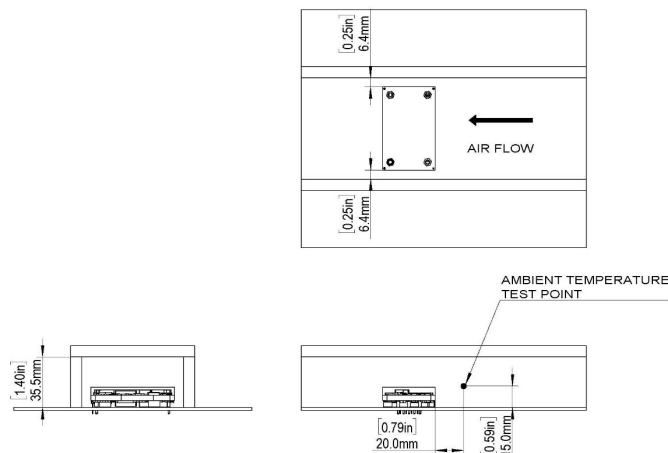



## MECHANICAL SPECIFICATIONS

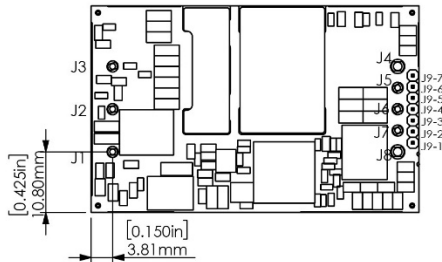
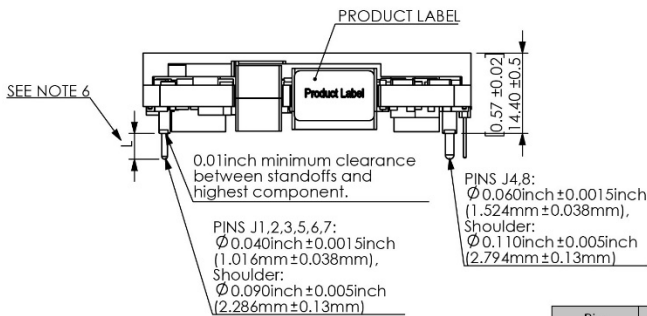
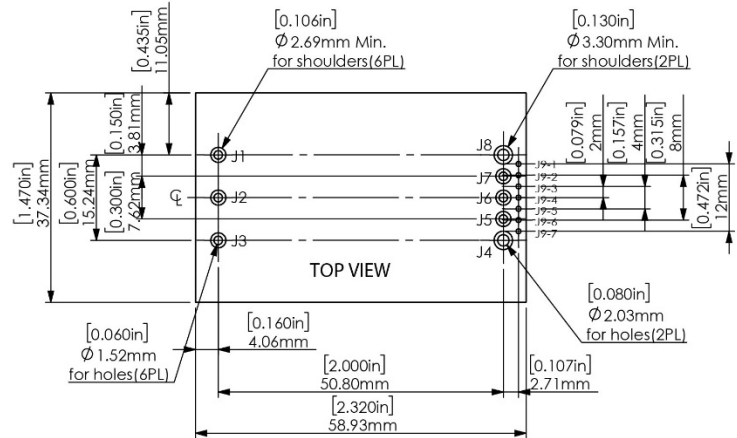
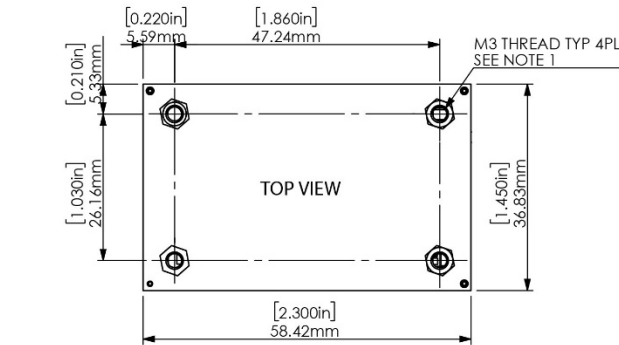

NOTES:  
UNLESS OTHERWISE SPECIFIED:  
1: M3 SCREW USED TO BOLT UNIT'S BASEPLATE TO OTHER SURFACES MUST NOT EXCEED 0.110"(2.8mm) DEPTH BELOW THE SURFACE OF BASEPLATE. APPLIED TORQUE PER SCREW SHOULD NOT EXCEED 5.3in-lb(0.6Nm)

2: FOR COSMETIC SPECIFICATION AND PRODUCTION WORKMANSHIP STANDARD, PLS FOLLOW THE FILE No. 60887.

3: ALL DIMENSIONS ARE IN INCHES(MILLIMETER).  
4: ALL TOLERANCES: x.xxxin, ±0.02in(x.xxxmm, ±0.5mm),  
x.xxxin, ±0.01in(x.xxxmm, ±0.25mm).

6: STANDARD PIN LENGTH: 0.180inch.

Pin	Designation
J1	Vin+
J2	On/Off
J3	Vin-
J4	Vout-
J5	Sense-
J6	Trim/C1
J7	Sense+
J8	Vout+
J9-1	Addr0
J9-2	Addr1
J9-3	Clock
J9-4	SMBAlert
J9-5	Data
J9-6	GND
J9-7	Pgood

### PIN DESCRIPTION

Pin	Name	Input/Output	Function
J1	Vin+	Input	MPQ600's positive (+) Input Voltage positive connection
J2	On/Off	Input	Remote on/off control of the main output. Pulled down to SIGNAL_GROUND to enable the main output and pull up or leave floating to disable (default); configurable via PMBus
J3	Vin-	Input	Input Voltage negative connection
J4	Vout-	Output	Converter's main output voltage return connection
J5	Sense-	Input	This signal can be connected to main output load "Vout -" to provide a degree of voltage compensation due of load connection drop
J6	Trim/C1	Input	Output voltage can be trimmed up or down by external resistor between Trim pin and either Sense pin up to the limits specified in output voltage characteristics table.
J7	Sense+	Input	This signal can be connected to main output load "Vout +" to provide a degree of voltage compensation due of load connection drop
J8	Vout+	Output	Converter's main output voltage + connection
J9-1	Addr0	Input	Connect resistor to GND to configure PMBUS address per "PMBus Addressing" details in the PMBus Section
J9-2	Addr1	Input	
J9-3	Clock	Input/Output	
J9-4	SMBALERT#	Output	This signal clears (changes to low logic state) when any of the DC-DC converter's supported STATUS_X register fault/warn bits are set. The intention is to provide system/host with indication of warning/fault condition, useful in situations the system host has not yet read the device's status, thus allowing the system to take immediate action.
J9-5	Data	Input/Output	
J9-6	SIGNAL_GND	Output	Signal return for PMBUS and PGood signals.
J9-7	PGood	Output	PGood signal is a negative logic signal that indicates the status of the main output. The PMBus TTL level: Output Low < 0.4V; Output High > 2.4V; Output sinking/sourcing current max: 4mA

**SHIPPING TRAYS AND BOXES**

ITEM NO. (95000050121)	PART NUMBER	DESCRIPTION	QTY
1	2300208	SHIPPING BOX, 10" X 10" X 2.50"	3
2	2300221	SHIPPING TRAY BASE (PAD).75" THICK	3 (NOTE 8)
3	2300234	SHIPPING TRAY, 1/4 BRICK (15 CAVITY)	6
4	2300159	LABEL, 1.0" X 1.5" PAPER	3
5	5600-01098-0	LABEL, PRE-PRINTED ESD ATTENTION	3
6	5652-01166-0	LABEL, PAPER, 2.0" X 4.0"	3 (NOTE 6)
7	6200-01211-0	ESD TAPE, 3/4" WIDE	1.0'
8	6256-01125-0	ESD PAD 335mm X 305mm	2
9	6256-01124-0	ESD PAD 335mm X 225mm	2
10	6256-01126-0	ESD PAD 255mm X 225mm	2
11	6256-01127-0	RIGHT ANGLE CLIP	4
12	6256-01671-0	SHIPPING BOX 350*320*290 WITH MPS LOGO	1

ITEM NUMBERS REFER TO 95000050121 BOM. ITEMS ABOVE ARE FOR REFERENCE ONLY. REFER TO APPROPRIATE BOM FOR COMPLETE LIST OF PARTS

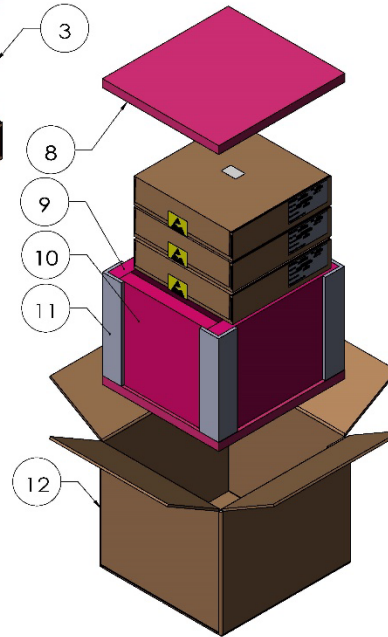
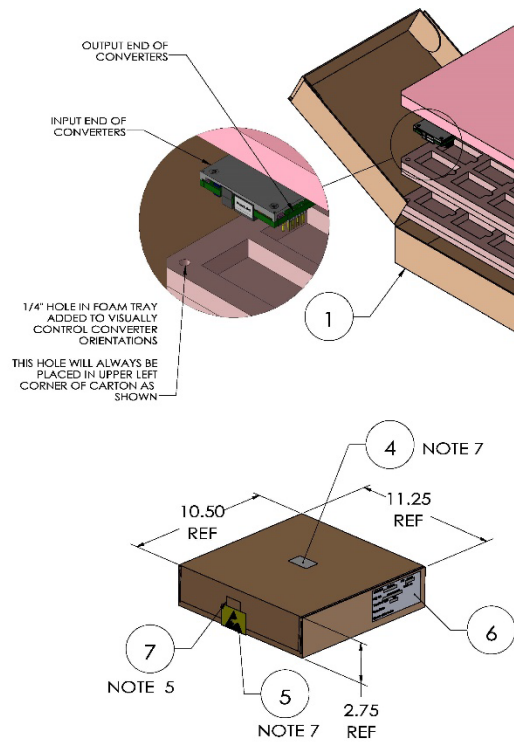
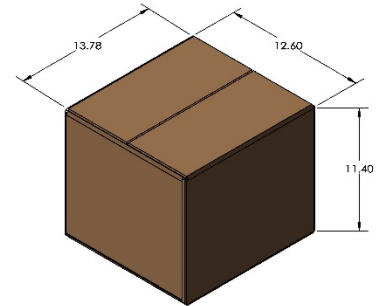

**NOTES:**

- THIS DOCUMENT DEFINES THE GENERAL PACKING RULES FOR APPLICABLE SHIPPING KIT. INFORMATION FOR SEALING AND MARKING IS NOT PART OF THIS DOCUMENT.
- REFER TO SHIPPING KIT BOM DETAILS.
- INSERT UNITS INTO FOAM POCKETS IN TRAYS APPROX AS SHOWN
- EACH FOAM TRAY (ITEM 3) CONTAINS 15 UNITS. EACH BOX (ITEM 1) CONTAINS 30 UNITS. IN FULL CARTON (ITEM 12) QUANTITIES, 3 BOXES (ITEM 1) EQUAL A TOTAL OF 90 UNITS.
- IF SHIPPING QTY IS 30PCS, PLEASE ALSO USE ITEM 12 TO MAKE THE PACKAGE(TWO EMPTY BOX ITEM 1) PUT ON THE BOX ITEM 1 WITH PRODUCTS.
- FRONT FLAP SHALL BE SEALED WITH ESD TAPE SPECIFIED OR EQUIVALENT AFTER THE BOX IS CLOSED.
- LABEL (ITEM 6) USED FOR MFR OVERPACK CARTON
- APPLY ESD LABEL (ITEM 5) OVER TAPE USED TO SEAL BOX AND APPLY IDENTIFICATION LABEL (ITEM 4) APPROX AS SHOWN.
- PAD (ITEM 2) MAY, AT MFR'S OPTION, BE EXCHANGED FOR THINNER PAD IF FOAM STACKUP EXCEEDS CARTON HEIGHT BY >1/8" OR ADDITIONAL PAD MAY BE ADDED IF STACKUP IS BELOW INSIDE CARTON HEIGHT BY >1/8"
- ALTERNATE PADS: 1/4" THK=2300216, 3/8" THK=2300218, 1/2" THK=2300219, 3/4" THK=2300221

**MPQ = 30**

## TECHNICAL NOTES & APPLICATIONS OVERVIEW

### Power Management Overview and PMBus Interface (Applicable Models)

A wide range of parameters can be read and configured by the system/host by using PMBus™ digital communications.

Each module is provided pre-configured for a wide range operation. Refer to the [PMBus™ Interface](#) section for details.

### SMBAERT# Hardware Signal (Applicable Models)

[SMBALERT#](#) signal offers an alternate method for system/host notification that a fault or Warning has been detected (mirrors the STATUS\_X fault/warn register bits) within the module and is useful in applications requiring real time fault notification independent or in addition to reading PMBus™ STATUS\_X register fault bits which may not be read by system/host frequently enough to detect that a fault/warning bit flag was set.

Internally driven low <0.4Vdc indicates a Vout, Iout, Vin, Temperature, or Power Good fault/warning has been detected and remains low until the fault/warning stimulus has been removed and the system/host clears the individual bit flag or issues "CLEAR\_FAULTS" command.

Drive high, >2.4Vdc to indicate no fault conditions within power module are detected.

### Soft-start Power Up

The default rise time of the ramp up is 30ms. When starting by applying input voltage the control circuit boot-up time adds an additional 10ms delay. The soft-start power up of the module can be reconfigured using the PMBus interface.

### Output Over Voltage Protection (OVP)

Both OVP limit and response can be configured via PMBus command (See PMBus Command 40h VOUT\_OV\_FAULT\_LIMIT [for details](#)). The default output OVP limit is set to 20% above nominal output voltage and responds by immediately shutdown of main output and occur, output is latch, to rectify the fault, need to restart enable or Vin.

### Over Current Protection (OCP, Current limit)

The module includes current limiting circuitry for protection at continuous over load. The default setting for the product is latch mode. The current limit can be configured by PMBus command 0x46, IOUT\_OC\_FAULT\_LIMIT, to be greater than the IOUT\_OC\_WARN\_LIMIT (PMBus Command 0x4A). The maximum value that the current limit could be set is 40A.

### Power Good

The module provides [Power Good](#) (PG) flag in the STATUS\_WORD register that indicates the output voltage is within a specified tolerance of its target level and no fault condition exists. The Power Good pin default logic is negative and it can be configured by MFR\_PGOOD\_POLARITY.

**CAUTION:** This converter is not internally fused. To avoid danger to persons or equipment and to retain safety certification, the user must connect an external fast-blow input fuse as listed in the specifications. Be sure that the PC board pad area and etch size are adequate to provide enough current so that the fuse will blow with an overload.

### Start Up Considerations

When power is first applied to the DC-DC converter, there is some risk of startup difficulties if you do not have both low AC and DC impedance and adequate regulation of the input source. Make sure that your source supply does not allow the instantaneous input voltage to go below the minimum voltage at all times. Use a moderate size capacitor very close to the input terminals. You may need two or more parallel capacitors. A larger electrolytic or ceramic cap supplies the surge current and a smaller parallel low-ESR ceramic cap gives low AC impedance.

Remember that the input current is carried both by the wiring and the ground plane return. Make sure the ground plane uses adequate thickness copper. Run additional bus wire if necessary.

### Input Fusing

Certain applications and/or safety agencies may require fuses at the inputs of power conversion components. Fuses should also be used when there is the possibility of sustained input voltage reversal which is not current-limited. For greatest safety, we recommend a fast blow fuse installed in the ungrounded input supply line.

## Input Under-Voltage Shutdown and Start-Up Threshold

Converters will not begin to fully regulate until the rising input voltage exceeds and remains at the Start-Up Threshold Voltage (see Specifications). Once operating, converters will not turn off until the input voltage drops below the Under-Voltage Shutdown Limit. Subsequent restart will not occur until the input voltage rises again above the Start-Up Threshold. This built-in hysteresis prevents any unstable on/off operation at a single input voltage. The over/under-voltage fault level and fault response and hysteresis can be configured via the PMBus interface. See commands 0x55 (VIN\_OV\_FAULT\_LIMIT) and 0x59 (VIN\_UV\_FAULT\_LIMIT) in the PMBus command list for additional details

## Start-Up Time

Turn-on time (see Specifications) is the time interval between the point when the rising input voltage crosses the Start-Up Threshold and the output voltage rises to within 10% of regulation point.

These converters include a soft start circuit to control Vout ramp time, thereby limiting the input inrush current.

The On/Off Remote Control interval from On command to Vout (final  $\pm 10\%$ ) assumes that the converter already has its input voltage stabilized above the Start-Up Threshold before the On command. The interval is measured from the On command until the output enters and remains within its specified accuracy band. See PMBus command 0x60 (TON\_DELAY) for additional configuration [details](#)

## Recommended Input Filtering

The user must assure that the input source has low AC impedance to provide dynamic stability and that the input supply has little or no inductive content, including long distributed wiring to a remote power supply. The converter will operate with no additional external capacitance if these conditions are met.

For best performance, we recommend installing a low-ESR capacitor immediately adjacent to the converter's input terminals. The capacitor should be a ceramic type such as the Murata GRM32 series or a polymer type. More input bulk capacitance may be added in parallel (either electrolytic or tantalum) if needed.

## Recommended Output Filtering

This series need minimum polymer capacitor to keep loop stabilization. However, the user may install external output capacitance to further improve ripple or for improved dynamic response, however low-ESR ceramic (Murata GRM32 series) or polymer capacitors must be used and mounted close to the converter using only as much capacitance as required to achieve your ripple and noise objectives. Excessive capacitance may make step load recovery sluggish and/or introduce instability. Never exceed the maximum rated output capacitance listed in the specifications.

## Input Ripple Current and Output Noise

All models in this converter series are tested and specified for input reflected ripple current and output noise using designated external input/output components, circuits and layout as shown in the figures below. The Cbus and Lbus components simulate a typical DC voltage bus.

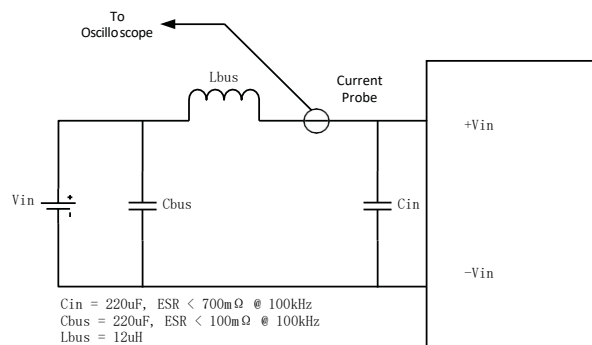

## Measuring Input Ripple Current

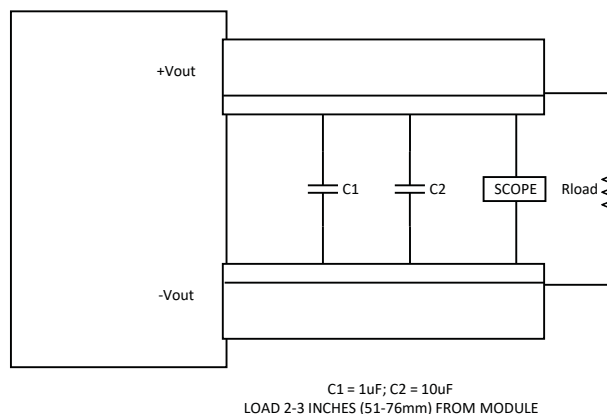

## Measuring Output Ripple and Noise (PARD)

### Minimum Output Loading Requirements

All models regulate within specification and are stable under no load to full load conditions.

### Thermal Shutdown (OTP)

This series includes thermal sense and shutdown circuitry that protects itself from overtemperature conditions. Upon detection of overtemperature condition defined by PMBus command 0x4F "OT\_FAULT\_LIMIT", the module enters OTP and shuts down. Once the temperature falls below restart threshold, as defined in PMBus command list, (OT\_FAULT\_LIMIT, 0x4F and MFR\_OT\_FAULT\_HYS, 0xEA), the module automatically restarts. OTP fault limit and recovery hysteresis are configurable via [PMBus](#).

CAUTION: If you operate too close to the thermal limits, the converter may shut down suddenly without warning. Be sure to thoroughly test your application to avoid unplanned thermal shutdown.

### Temperature Derating Curves

The graphs in this data sheet illustrate typical operation under a variety of conditions. The Derating curves show the maximum continuous ambient air temperature and decreasing maximum output current which is acceptable under increasing

forced airflow measured in Linear Feet per Minute (“LFM”). Note that these are AVERAGE measurements. The converter will accept brief increases in current or reduced airflow as long as the average is not exceeded.

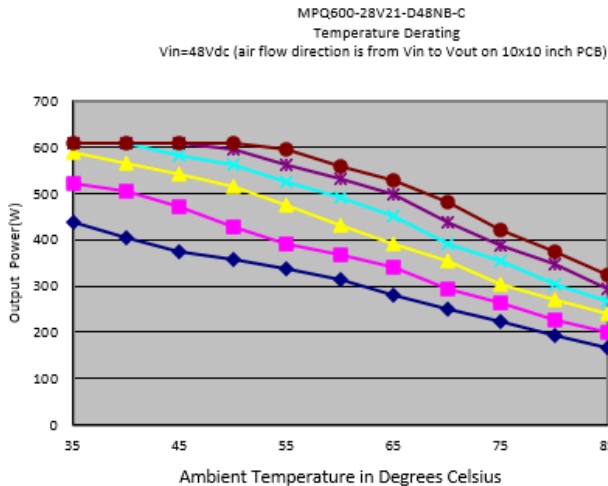

Note that the temperatures are of the ambient airflow, not the converter itself which is obviously running at higher temperature than the outside air. Also note that “natural convection” is defined as very low flow rates which are not using fan-forced airflow. Depending on the application, “natural convection” is usually about 30-65 LFM but is not equal to still air (0 LFM).

Murata Power Solutions makes Characterization measurements in a closed cycle wind tunnel with calibrated airflow. We use both thermocouples and an infrared camera system to observe thermal performance. As a practical matter, it is quite difficult to insert an anemometer to precisely measure airflow in most applications. Sometimes it is possible to estimate the effective airflow if you thoroughly understand the enclosure geometry, entry/exit orifice areas and the fan flow rate specifications.

CAUTION: If you exceed these Derating guidelines, the converter may have an unplanned Over Temperature shut down. Also, these graphs are all collected near Sea Level altitude. Be sure to reduce the derating for higher altitude.

### Output Short Circuit Condition

The short circuit condition is an extension of the “Current Limiting” condition. When the monitored peak current signal reaches a certain range, the PWM controller’s outputs are shut off thereby turning the converter “off.” This is followed by an extended time out period. This period can vary depending on other conditions such as the input voltage level. Following this time out period, the PWM controller will attempt to re-start the converter by initiating a “normal start cycle” which includes soft start. If the “fault condition” persists, another “hiccup” cycle is initiated. This “cycle” can and will continue indefinitely until such time as the “fault condition” is removed, at which time the converter will resume “normal operation.” Operating in the “hiccup” mode during a fault condition is advantageous in that average input and output power levels are held low preventing excessive internal increases in temperature.

### Remote On/Off Control

The MPQ series modules are equipped with an [On/Off control pin](#) (internal pull up, TTL open-collector and/or CMOS open-drain compatible) and is configurable via PMBus interface. Output is enabled when the On/Off is grounded or brought to within a low voltage (see specifications) with respect to –Vin. The device is off (disabled) when the On/Off is left open or is pulled high to +13.5Vdc with respect to –Vin. The On/Off function allows the module to be turned on/off by an external device switch.

The restart delay for this module to turn On/Off by the On/Off control pin is 200ms.

On/Off can be configured by PMBus command `0xDD` (MFR\_PRIMARY\_ON\_OFF\_CONFIG); default configuration does not ignore the control pin and therefore requires the On/Off control pin to be asserted to start the unit.

On/Off status is dependent on On/Off control and OPERATION (PMBus command) status; both must be ON to turn MPQ on; if one of them is OFF, unit will be returned off.

### Output Capacitive Load

These converters require external minimum capacitance added to achieve rated specifications. Users should consider adding capacitance to reduce switching noise and/or to handle spike current load steps. Install only enough capacitance to achieve noise objectives. Excess external capacitance may cause degraded transient response and possible oscillation or instability.

### Remote Sense Input

Use the [Sense inputs](#) with caution. Sense is normally connected at the load. Sense inputs compensate for output voltage inaccuracy delivered at the load. This is done by correcting IR voltage drops along the output wiring and the current carrying capacity of PC board etches. This output drop (the difference between Sense and Vout when measured at the converter) should not exceed 0.5V. Consider using heavier wire if this drop is excessive. Sense inputs also improve the stability of the converter and load system by optimizing the control loop phase margin.

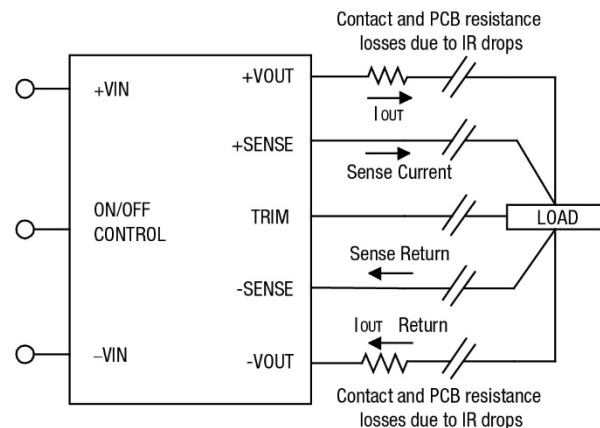

Remote Sense Circuit Configuration



Note: The Sense input and power Vout lines are internally connected through low value resistors to their respective polarities so that the converter can operate without external connection to the Sense. Nevertheless, if the Sense function is not used for remote regulation, the user should connect +Sense to +Vout and -Sense to -Vout at the converter pins.

The remote Sense lines carry very little current. They are also capacitively coupled to the output lines and therefore are in the feedback control loop to regulate and stabilize the output. As such, they are not low impedance inputs and must be treated with care in PC board layouts. Sense lines on the PCB should run adjacent to DC signals, preferably Ground. In cables and discrete wiring, use twisted pair, shielded tubing or similar techniques.

Any long, distributed wiring and/or significant inductance introduced into the Sense control loop can adversely affect overall system stability. If in doubt, test your applications by observing the converter's output transient response during step loads. There should not be any appreciable ringing or oscillation. You may also adjust the output trim slightly to compensate for voltage loss in any external filter elements. Do not exceed maximum power ratings.

Please observe Sense inputs tolerance to avoid improper operation:

$$|Vout(+)-Vout(-)| - |Sense(+)-Sense(-)| \leq 10\% \text{ of } Vout$$

Output overvoltage protection is monitored at the output voltage pin, not the Sense pin. Therefore, excessive voltage differences between Vout and Sense together with trim adjustment of the output can cause the overvoltage protection circuit to activate and shut down the output.

Power derating of the converter is based on the combination of maximum output current and the highest output voltage. Therefore, the designer must ensure:

$$(Vout \text{ at pins}) \times (Iout) \leq (\text{Max. rated output power})$$

### Soldering Guidelines

Murata Power Solutions recommends the specifications below when installing these converters. These specifications vary depending on the solder type. Exceeding these specifications may cause damage to the product. Be cautious when there is high atmospheric humidity. We strongly recommend a mild pre-bake (100° C for 30 minutes). Your production environment may differ; therefore, please thoroughly review these guidelines with your process engineers.

Wave Solder Operation for Through-Hole Mounted Products (THMT)	
<b>For Sn/Ag/Cu based solders:</b>	
Maximum Preheat Temperature	115
Maximum Pot Temperature	270
Maximum Solder Dwell Time	7 seconds
<b>For Sn/Pb based solders:</b>	
Maximum Preheat Temperature	105
Maximum Pot Temperature	250
Maximum Solder Dwell Time	6 seconds

### Trimming the Output Voltage

The Trim input pin is used to adjust the output voltage over the rated trim range (please refer to the Specifications). As illustrated in the trim equations and circuit diagrams below, trim adjustments use a single fixed resistor connected between the Trim input and either Vout Sense pin. Trimming resistors should have a low temperature coefficient ( $\pm 100$  ppm/deg.C or less) and be mounted close to the converter keeping leads short. If the trim function is not used, leave the trim unconnected, the converter will default to its specified output voltage accuracy.

#### CAUTION:

1. Avoid activating shutdown protection (OVP, OCP, OTP) by ensuring the output voltage or output power is not exceeded when setting the output voltage trim.
2. Keep the trim external connections as short as possible to avoid excessive noise that may otherwise cause instability or oscillation using shielding if needed.

### Trim Equations

#### Trim Up: Connect Trim (Pin #J6) to +Vout Sense (Pin #J7)

$$R_{t \text{ up}}(k\Omega) = 1 * V_{nom} * (1 + \Delta) / (1.225 * \Delta) - 1 / \Delta - 2$$

$$\Delta = (V_{nom} - V_o) / V_{nom}$$

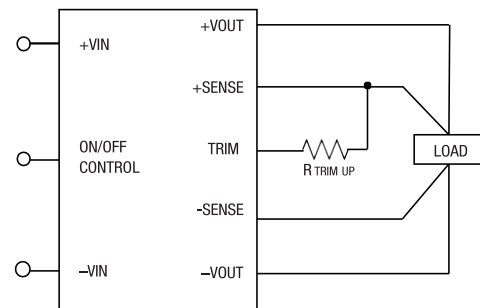

#### Trim Down: Connect Trim (Pin #J6) to -Vout Sense (Pin #J5)

$$R_{t \text{ down}}(k\Omega) = 1 / ((V_{nom} - V_o) / V_{nom}) - 2$$

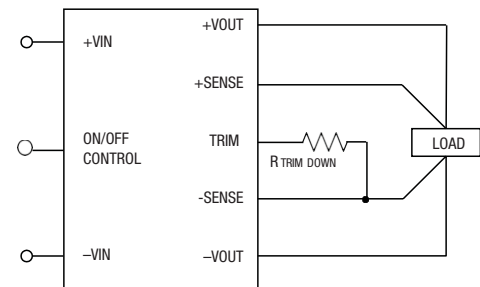

**NOTE:** Adjustment accuracy is subject to resistor tolerances and factory-adjusted output accuracy. Mount trim resistor close to converter. Use short leads.

**Output Voltage Adjust**

The output voltage may be adjusted using a voltage applied to the Vadj pin through a resistor Radj. This voltage is calculated by using the following equation.

$$V_{adj} = \left( 1.225 + (R_{adj} + 2) \times 1.225 \times \frac{V_{desired} - 28}{28} \right) \text{ V}$$

Vdesired: desired (trimmed) output voltage (V)  
Vadj: the external trim voltage (V)  
Radj: the external trim resistor (kΩ)

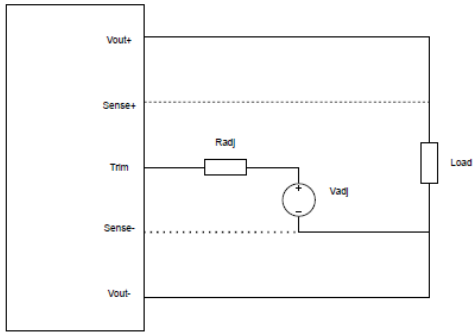

Active Adjust

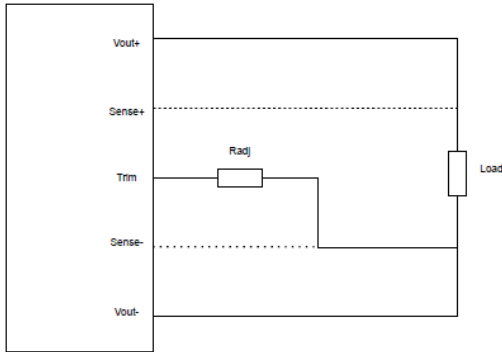

Passive Adjust Decrease

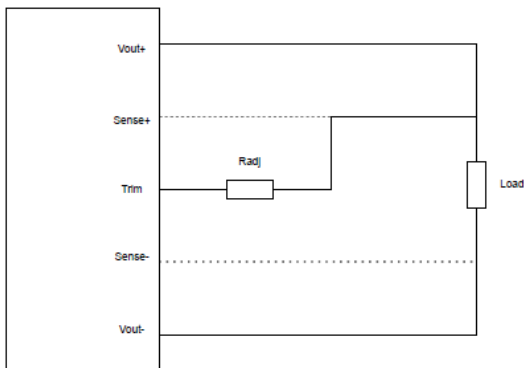

Passive Adjust Increase

### Emissions Performance

Murata Power Solutions measures its products for conducted emissions against the EN 55022 and CISPR 22 standards. Passive resistance loads are employed and the output is set to the maximum voltage. If you set up your own emissions testing, make sure the output load is rated at continuous power while doing the tests.

The recommended external input and output capacitors (if required) are included. Please refer to the fundamental switching frequency. All of this information is listed in the Product Specifications. An external discrete filter is installed and the circuit diagram is shown below.

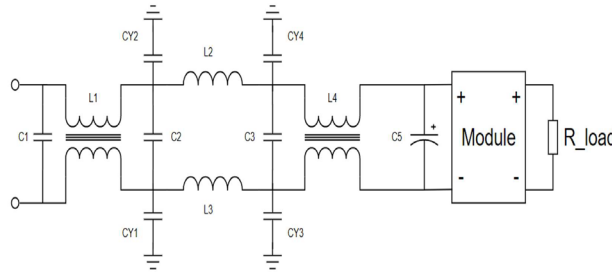

### [1] Conducted Emissions Parts List

Reference	Description
C1	0.47uF
C2	0.47uF
C3	0.47uF
C5	220uF (e-lyt)
CY1, CY2	2.2nF
CY3, CY4	4.7nF
L1, L4	5mH
L2, L3	11uH

### [2] Conducted Emissions Test Equipment Used

Hewlett Packard HP8594L Spectrum Analyzer – S/N 3827A00153  
2Line V-networks LS1-15V 50Ω/50uH Line Impedance Stabilization Network

### 3] Conducted Emissions Test Results – Negative Line

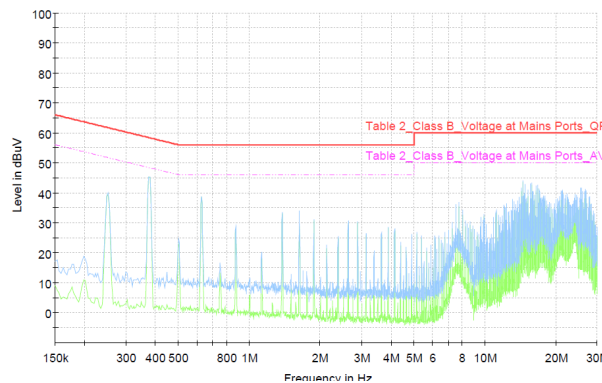

Conducted Emissions Performance, Negative Line  
CISPR 22, Class B, Full Load

### [4] Layout Recommendations

Most applications can use the filtering which is already installed inside the converter or with the addition of the recommended external capacitors. For greater emissions suppression, consider additional filter components and/or shielding. Emissions performance will depend on the user's PC board layout, the chassis shielding environment and choice of external components. Since many factors affect both the amplitude and spectra of emissions, we recommend using an engineer who is experienced at emissions suppression.



### PMBus™ Digital Communications Protocol

This module offers a PMBus digital interface that enables the user to configure many characteristics of the device operation as well as to monitor the input and output voltages, output current and device temperature. The module can be used with any standard two-wire I<sup>2</sup>C or SMBus host device.

A system controller (host device) can monitor a wide variety of parameters through the PMBus interface and detect fault conditions by monitoring the SMBALERT# pin, which will be asserted when any number of pre-configured fault or warning conditions occurs. The system controller can also continuously monitor any number of power conversion parameters including but not limited to the following:

- [1] Input voltage
- [2] Output voltage
- [3] Output current
- [4] Module temperature

### Software Tools for Design and Production

For these modules, Murata-PS provides software for configuring and monitoring via the PMBus interface. For more information, please contact your local Murata-PS representative.

### Standard PMBus™ characteristics

- Complies with “Power Systems Management Protocol Specification Part 1 General Requirements Transport and Electrical requirements revision 1.2” & “Power Systems Management Protocol Specification Part 2 Command Language revision 1.2”
- Linear data format is used for all supported parameters unless noted
- Up to 400kHz I<sup>2</sup>C communications bus speed is supported
- SMBALERT## is supported
- PEC is supported
- Clock stretching is supported

### PMBus™ Monitoring Accuracy

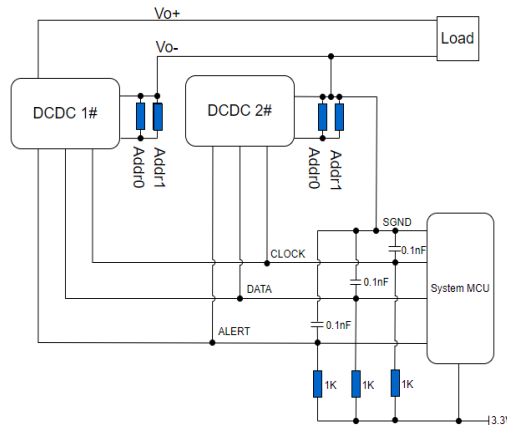

Parameter	Notes and Conditions	Min.	Typ.	Max.	Units
<b>PMBus</b>					
<b>PMBus General</b>					
Bus Speed				400	kHz
Logic High Input		2.1		3.3	Vdc
Logic Low Input		0		0.8	Vdc
Logic High Output		2.3			Vdc
Logic Low Output				0.4	Vdc
<b>PMBus Monitoring Accuracy</b>					
VIN_READ		-1.5		1.5	V
VOUT_READ		-2		2	%
IOUT_READ	Vin=48V, Io=50% ~ 100% of Io, max;	-5		5	%
	Vin=48V, Io=5% ~ 50% of Io, max;	-3		3	A
TEMP_READ		-10		10	°C

## PMBus Addressing

This power module series offers three address configurations to support a wide range of applications. The address is set by externally connecting two resistors from each of the two address pins “Addr1” and “Addr0” to signal ground “Sig\_Gnd” and forms two octal (0 to 7) digits, each pin setting one digit. The resistor value for each digit is defined according to the desired configuration.

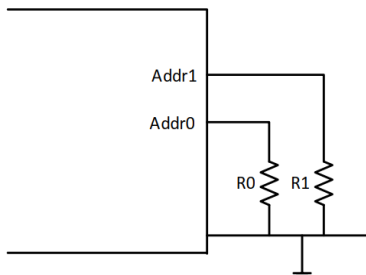

**Addressing configuration 0 (default):** If the calculated PMBus address is 0~12D, 40D, 44D, 45D or 55D, SA0 or SA1 lefts open, default PMBus address 127D is assigned instead.

$$\text{PMBus\_Address} = 8x (\text{SA1 index}) + (\text{SA0 index})$$

Digit	Resistor Value R <sub>SA0</sub> /R <sub>SA1</sub> [kΩ]
0	10
1	15.4
2	23.7
3	36.5
4	54.9
5	84.5
6	130
7	200

Calculation: PMBus\_Address = 8x (SA1 index) + (SA0 index)

**Addressing configuration 0 (default):** If the calculated PMBus address is 0D, 11D, 12D, SA0 or SA1 lefts open, default PMBus address 119D is assigned instead.

$$\text{PMBus\_Address} = 8x (\text{SA0 index}) + (\text{SA1 index})$$

Digit	Resistor Value R <sub>SA0</sub> /R <sub>SA1</sub> [kΩ]
0	10
1	22
2	33
3	47
4	68
5	100
6	150
7	220

Calculation: PMBus\_Address = 8 x (SA0 value) + (SA1 value)

**Addressing configuration 0 (default):** If the calculated PMBus address is 0~12D, 40D, 44D, 45D or 55D, SA0 or SA1 lefts open, default PMBus address 88D is assigned instead.

$$\text{PMBus\_Address} = 16x \text{Addr1} + \text{Addr0}$$

Digit	Resistor Value R <sub>SA0</sub> /R <sub>SA1</sub> [kΩ]
0	24.9
1	49.9
2	75
3	100
4	124
5	150
6	174
7	200

Calculation: PMBus\_Address = 16 x Addr1 + Addr0

**NOTE:** Follow these steps to change the power module address configuration

- 1) Select the desired address configuration via PMBus command 0xF5.
- 2) Save configuration to non-volatile user store memory by writing command 0x15 “STORE\_USER\_ALL”.
- 3) Recycle input power

## Supported PMBus™ Command List

CMD	Command Name	SMBus Transaction Type: Writing Data	SMBus Transaction Type: Reading Data	Number Of Data Bytes	Default Value	Lower limit	Upper limit	Unit	Note	
01h	OPERATION	Write Byte	Read Byte	1	0x80				Only support 0x80 and 0x00	
02h	ON_OFF_CONFIG	Write Byte	Read Byte	1	0x1D				Bit7~5 : Reserved, Fixed 000; Bit4 : Fixed 1; Bit3~2: 01: enable 10 : pmbus 11 : enable&pmbus Bit1~0: Reserved	
03h	CLEAR_FAULTS	Send byte	N/A	0	N/A					
10h	WRITE_PROTECT	Write Byte	Read Byte	1	0x00				Only support : 0x00 / 0x20 / 0x40 / 0x80	
11h	STORE_DEFAULT_ALL	N/A	N/A	0	N/A					
12h	RESTORE_DEFAULT_ALL	Send byte	N/A	0	N/A					
15h	STORE_USER_ALL	Send byte	N/A	0	N/A					
16h	RESTORE_USER_ALL	Send byte	N/A	0	N/A					
19h	CAPABILITY	N/A	Read Byte	1	0xB0					
1Ah	QUERY	N/A	"Block Write - Block Read Process Call"	1						
1Bh	SMBALERT_MASK	Write Word	"Block Write - Block Read Process Call"	2						
20h	VOUT_MODE	N/A	Read Byte	1	0x17					
21h	VOUT_COMMAND	Write Word	Read Word	2	0x1800	28	14	35	V	
22h	VOUT_TRIM	Write Word	Read Word	2	0	-14	7	V	Effective after turn off then to turn back on	
35h	VIN_ON	Write Word	Read Word	2		34		V		
36h	VIN_OFF	Write Word	Read Word	2		30		V		
40h	VOUT_OV_FAULT_LIMIT	Write Word	Read Word	2	0x1C00	38.0	35.0	38.0	V	
41h	VOUT_OV_FAULT_RESPONSE	Write Byte	Read Byte	1	0x80				Default latch mode	
42h	VOUT_OV_WARN_LIMIT	Write Word	Read Word	2	0x1B00	35.5	35.0	38.0	V	
43h	VOUT_UV_FAULT_LIMIT	Write Word	Read Word	2	0x1066	12.5	10.5	14.0	V	
44h	VOUT_UV_FAULT_RESPONSE	Write Byte	Read Byte	1	0xF8				Default latch mode	
45h	VOUT_UV_WARN_LIMIT	Write Word	Read Word	2	0x1599	13.5	10.5	14.0	V	
46h	IOUT_OC_FAULT_LIMIT	Write Word	Read Word	2	0xE1E0	26.0	23.5	28.5	A	
47h	IOUT_OC_FAULT_RESPONSE	Write Byte	Read Byte	1	0x80				Default latch mode	
4Ah	IOUT_OC_WARN_LIMIT	Write Word	Read Word	2	0xE1C0	24.0	21.5	26.5	A	
4Fh	OT_FAULT_LIMIT	Write Word	Read Word	2	0x0078	110	30	130	°C	Default value of with "B" suffix: 120°C
50h	OT_FAULT_RESPONSE	Write Byte	Read Byte	1	0xF8				Default hiccup mode	
51h	OT_WARN_LIMIT	Write Word	Read Word	2	0x0071	105	30	130	°C	
55h	VIN_OV_FAULT_LIMIT	Write Word	Read Word	2	0xEA6C	77.50	75.00	80.00	V	
56h	VIN_OV_FAULT_RESPONSE	Write Byte	Read Byte	1	0xF8				Default hiccup mode	
57h	VIN_OV_WARN_LIMIT	Write Word	Read Word	2	0xEA60	76.0	75.0	80.0	V	
58h	VIN_UV_WARN_LIMIT	Write Word	Read Word	2	0xE884	35.0	30.0	36.0	V	
59h	VIN_UV_FAULT_LIMIT	Write Word	Read Word	2	0xE880	32.0	30.0	36.0	V	
5Ah	VIN_UV_FAULT_RESPONSE	Write Byte	Read Byte	1	0xF8				Default hiccup mode	

5Eh	POWER_GOOD_ON	Write Word	Read Word	2	0x1466	13.500	1.000	14.000	V	
5Fh	POWER_GOOD_OFF	Write Word	Read Word	2	0x10CC	12.500	1.000	14.000	V	
61h	TON_RISE	Write Word	Read Word	2	0x003C	75	20	100	ms	
68h	POUT_OP_FAULT_LIMIT	Write Word	Read Word	2	0x0168	728	602	800	W	
69h	POUT_OP_FAULT_RESPONSE	Write Byte	Read Byte	2	0x80					Default latch mode
6Ah	POUT_OP_WARN_LIMIT	Write Word	Read Word	2	0x014A	670	602	800	W	
78h	STATUS_BYTE	Write Byte	Read Byte	1	N/A					
79h	STATUS_WORD	Write Word	Read Word	2	N/A					
7Ah	STATUS_VOUT	Write Byte	Read Byte	1	N/A					
7Bh	STATUS_IOUT	Write Byte	Read Byte	1	N/A					
7Ch	STATUS_INPUT	Write Byte	Read Byte	1	N/A					
7Dh	STATUS_TEMPERATURE	Write Byte	Read Byte	1	N/A					
7Eh	STATUS_CML	Write Byte	Read Byte	1	N/A					
88h	READ_VIN	N/A	Read Word	2	N/A				V	
8Bh	READ_VOUT	N/A	Read Word	2	N/A				V	
8Ch	READ_IOUT	N/A	Read Word	2	N/A				A	
8Dh	READ_TEMPERATURE_1	N/A	Read Word	2	N/A				°C	
94h	READ_DUTY_CYCLE	N/A	Read Word	2	N/A				%	
95h	READ_FREQUENCY	N/A	Read Word	2	N/A				kHz	
96h	READ_POUT	N/A	Read Word	2	N/A				W	
98h	PMBUS_REVISION	N/A	Read Byte	1	0x22					
99h	MFR_ID	N/A	Block Read	22	"Murata Power Solutions"					
9Ah	MFR_MODEL	Block Write*	Block Read	<=20	N/A					
9Bh	MFR_REVISION	Block Write*	Block Read	<=10	N/A					
9Ch	MFR_LOCATION	Block Write*	Block Read	<=10	N/A					
9Dh	MFR_DATE	Block Write*	Block Read	<=10	N/A					
9Eh	MFR_SERIAL	Block Write*	Block Read	<=20	N/A					
A0h	MFR_VIN_MIN	N/A	Read Word	2	0xE890	36			V	
A1h	MFR_VIN_MAX	N/A	Read Word	2	0xEA58	75			V	
A2h	MFR_IIN_MAX	N/A	Read Word	2	0xDA80	20			A	
A3h	MFR_PIN_MAX	N/A	Read Word	2	0x014F	672			W	
A4h	MFR_VOUT_MIN	N/A	Read Word	2	0x1333	14			V	
A5h	MFR_VOUT_MAX	N/A	Read Word	2	0x1A66	35			V	
A6h	MFR_IOUT_MAX	N/A	Read Word	2	0xE8C8	22			A	
A7h	MFR_POUT_MAX	N/A	Read Word	2	0x012C	602			W	
A8h	MFR_TAMBIENT_MAX	N/A	Read Word	2	0x0055	85			°C	
A9h	MFR_TAMBIENT_MIN	N/A	Read Word	2	0X078D	-40			°C	
ADh	IC_DEVICE_ID	N/A	Block Read		"TMS320F280023"					
C0h	MFR_MAX_TEMP_1	N/A	Write Word	2	0x0082	130			°C	
DAh	Erase EEPROM	Write Word	N/A	2	N/A					
DDh	MFR_ENABLE_POLARITY_CONFIG	Write Byte*	Read Byte	1	0x00					Default value of negative logic: 0x00 Default value of positive logic: 0x02

DEh	MFR_PGOOD_POLARITY	Write Byte	Read Byte	1	0x01					Default value of negative logic: 0x00 Default value of positive logic: 0x01
DFh	MFR_BLACKBOX_CONFIG_BYTE	Write Byte*	Write Byte	1	0x03					Bit0: Blackbox Enable Bit1: Rewrite Enable
E0h	MFR_BLACKBOX_EVENT	N/A	Block Read	32						
E1h	MFR_BLACKBOX_OFFSET	Write Byte*	Write Byte	1						
E8h	MFR_VIN_OV_FAULT_HYS	Write Word*	Read Word	2	0xE808	2.00	0.20	4.00	V	
E9h	MFR_VIN_UV_FAULT_HYS	Write Word*	Read Word	2	0xE808	2.00	0.20	4.00	V	
EAh	MFR_OT_FAULT_HYS	Write Word*	Read Word	2	0x000A	10	5	50	°C	
F5h	MFR_PMBUS_ADDRESS_CONFIG	Write Byte*	N/A	32	N/A					
F6h	MFR_CALIBRATION_STATUS	N/A	Read Byte	1	0x07					
F9h	MFR_VIN_SENSE_CALIBRATION	Write byte*	N/A	1	N/A					
FAh	MFR_IOUT_SENSE_CALIBRATION	Write Word*	N/A	2	N/A					
FBh	MFR_VOUT_SET_POINT_CALIBRATION	Write Word*	N/A	2	N/A					
FCh	MFR_SUPERVISOR_PASSWORD	Block Write*	N/A	N/A	N/A					

#### NOTES:

\*) Only available in supervisor mode (default state is user mode, send password to command 0xFC to change to supervisor mode)

- 1) Unit restores the entire contents of the non-volatile User Store memory when power up
- 2) PEC is supported
- 3) Max bus speed: 400kHz
- 4) SMBALERT# is supported
- 5) Linear data format used

## MFR Commands

### DAh Erase EEPROM

BITS	VALUE	ERASE MODE	MEANING
15:12	0001	The erase object is all content	<b>Erase all Content</b>
	0010	The erase object is block	<b>Erase block</b>
	0011	The erase object is page	<b>Erase page</b>
11:8	0000	Select block 0, or block 1 to be erased	<b>Erase block 0</b>
	0001		<b>Erase block 1</b>
7:1	0000	Select the specific page from page 0 to page 15 to be erased.	<b>Erase page 0</b>
	0001		<b>Erase page 1</b>
	0010		<b>Erase page 2</b>
	.....		.....
	1101		<b>Erase page 13</b>
	1110		<b>Erase page 14</b>
	1111		<b>Erase page 15</b>

Block 0	Block 1
Page 0	Page 0
Page 1	Page 1
Page 2	Page 2
.....	.....
Page 13	Page 13
Page 14	Page 14
Page 15	Page 15

EEPROM data structure

### DDh MFR\_PRIMARY\_ON\_OFF\_CONFIG

BITS	PURPOSE	VALUE	MEANING
7:3		00000	Reserved
2	Controls how the unit responds to the CONTROL pin	0	Unit ignores the primary ON/OFF pin
		1	Unit requires the primary ON/OFF pin to be asserted to start the unit
1	Polarity of primary ON/OFF logic	0	Active low (Pull pin low to start the unit)
		1	Active high (Pull high or open to start the unit)
0		0	Reserved

### DEh MFR\_PGOOD\_POLARITY

BITS	PURPOSE	VALUE	MEANING
7:1		000000	Reserved
0	Power good polarity of pin 12	0	Negative logic, output low if Vout rises to specific value
		1	Positive logic, output high if Vout rises to specific value

### E8h MFR\_VIN\_OV\_FAULT\_HYS

Hysteresis of VIN\_OV\_FAULT recover, Linear data format

### E9h MFR\_VIN\_UV\_FAULT\_HYS

Hysteresis of VIN\_UV\_FAULT recover, Linear data format

### EAh MFR\_OT\_FAULT\_HYS

Hysteresis of OT\_FAULT recover, Linear data format

## F3h MFR\_FAULT\_STATUS

Real-time fault status

Bits	Meaning
15	VIN_OV_FAULT
14	VIN_UV_FAULT
13	RSVD
12	RSVD
11	RSVD
10	VOUT_OV_FAULT
9	VOUT_OV_FAST_FAULT
8	RSVD

Bits	Meaning
7	IOUT_OC_FAULT
6	IOUT_SHORT_FAULT
5	OUTPUT_POWER_FAULT
4	OT_FAULT
3	PRI_ENABLE_OFF
2	PMBUS_OPERATION_OFF
1	RSVD
0	MINI_OFF_TIME

## F4h MFR\_FAULT\_COUNTER

Bits  
15:0

How many faults was occurred all the time

Max counter 65535, will start over from 0 if exceeds this number

Duplicate failure will not be counted, for example: continuous hiccup will be counted as 1 time fault

## F5h MFR\_EVENT\_LOG

## F6h MFR\_CALIBRATION\_STATUS

Refer to calibration procedure file

## F9h MFR\_VIN\_SENSE\_CALIBRATION

Refer to calibration procedure file

Step.x	Vin calibrate point (V)	Write Byte
Step 1	38	0x01
Step 2	50	0x02
Step 3	62	0x03
Step 4	74	0x04

## FAh MFR\_IOUT\_SENSE\_CALIBRATION

Refer to calibration procedure file

## FBh MFR\_VOUT\_SET\_POINT\_CALIBRATION

Refer to calibration procedure file

## FCh MFR\_SUPERVISOR\_PASSWORD

Set unit to supervisor mode or ROM mode, Refer to password table

## Status Register Bit Names

GREEN = supported

STATUS_VOUT
7 VOUT_OV_FAULT
6 VOUT_OV_WARNING
5 VOUT_UV_WARNING
4 VOUT_UV_FAULT
3 VOUT_MAX Warning
2 TON_MAX_FAULT
1 TOFF_MAX_WARNING
0 VOUT Tracking Error

STATUS_IOUT
7 IOUT_OC_FAULT
6 IOUT_OC_LV_FAULT
5 IOUT_OC_WARNING
4 IOUT_UC_FAULT
3
2 In Power Limiting Mode
1 POUT_OP_FAULT
0 POUT_OP_WARNING

STATUS_TEMPERATURE
7 OT_FAULT
6 OT_WARNING
5 UT_WARNING
4 UT_FAULT
3 Reserved
2 Reserved
1 Reserved
0 Reserved

STATUS_CML
7 Invalid/Unsupported Command
6 Invalid/Unsupported Data
5 Packet Error Check Failed
4 Memory Fault Detected
3 Processor Fault Detected
2 Reserved
1 Other Communication Fault
0 Other Memory Or Logic Fault

STATUS_WORD
7 VOUT
6 IOUT/POUT
5 INPUT
4 MFR_SPECIFIC
3 POWER_GOOD#
2 FANS
1 OTHER
0 UNKNOWN
7 BUSY
6 OFF
5 VOUT_OV_FAULT
4 IOUT_OC_FAULT
3 VIN_UV_FAULT
2 TEMPERATURE
1 CML
0 NONE OF THE ABOVE

STATUS_OTHER
7 Reserved
6 Reserved
5 Input A Fuse/Breaker Fault
4 Input B Fuse/Breaker Fault
3 Input A OR-ing Device Fault
2 Input B OR-ing Device Fault
1 Output OR-ing Device Fault
0 Reserved

STATUS_INPUT
7 VIN_OV_FAULT
6 VIN_OV_WARNING
5 VIN_UV_WARNING
4 VIN_UV_FAULT
3 Unit Off For Low Input Voltage
2 IIN_OC_FAULT
1 IIN_OC_WARNING
0 PIN_OP_WARNING

STATUS_MFR_SPECIFIC
Manufacturer Defined
Manufacturer Defined
Manufacturer Defined
Manufacturer Defined
Manufacturer Defined
Manufacturer Defined
Manufacturer Defined
Manufacturer Defined
Manufacturer Defined

STATUS_FANS_1_2
7 Fan 1 Fault
6 Fan 2 Fault
5 Fan 1 Warning
4 Fan 2 Warning
3 Fan 1 Speed Override
2 Fan 2 Speed Override
1 Air Flow Fault
0 Air Flow Warning

STATUS_FANS_3_4
7 Fan 3 Fault
6 Fan 4 Fault
5 Fan 3 Warning
4 Fan 4 Warning
3 Fan 3 Speed Override
2 Fan 4 Speed Override
1 Reserved
0 Reserved



## Command Language and Configuration Details:

01-CFh Refer to PMBUS 1.2 SPEC

### DDh MFR\_PRIMARY\_ON\_OFF\_CONFIG

Bits	Purpose	Value	Meaning
7:3		00000	Reserved
2	Controls how the unit responds to the CONTROL pin	0	Unit ignores the primary ON/OFF pin
		1	Unit requires the primary ON/OFF pin to be asserted to start the unit.
1	Polarity of primary ON/OFF logic	0	Active low (Pull pin low to start the unit)
		1	Active high (Pull high or open to start the unit)
0		0	Reserved

### DEh MFR\_PGOOD\_POLARITY

Bits	Purpose	Value	Meaning
7:1		0000000	Reserved
0	Power good polarity of pin 12	0	Negative logic, output low if Vout rises to specific value
		1	Positive logic, output high if Vout rises to specific value

### E8h MFR\_VIN\_OV\_FAULT\_HYS

Hysteresis of VIN\_OV\_FAULT recover, Linear data format

### E9h MFR\_VIN\_UV\_FAULT\_HYS

Hysteresis of VIN\_UV\_FAULT recover, Linear data format

### EAh MFR\_OT\_FAULT\_HYS

Hysteresis of OT\_FAULT recover, Linear data format

### F6h MFR\_CALIBRATION\_STATUS

Refer to calibration procedure file

### F9h MFR\_VIN\_SENSE\_CALIBRATION

Refer to calibration procedure file

### FAh MFR\_IOUT\_SENSE\_CALIBRATION

Refer to calibration procedure file

### FBh MFR\_VOUT\_SET\_POINT\_CALIBRATION

Refer to calibration procedure file

### FCh MFR\_SUPERVISOR\_PASSWORD

Set unit to supervisor mode or ROM mode, Refer to password table

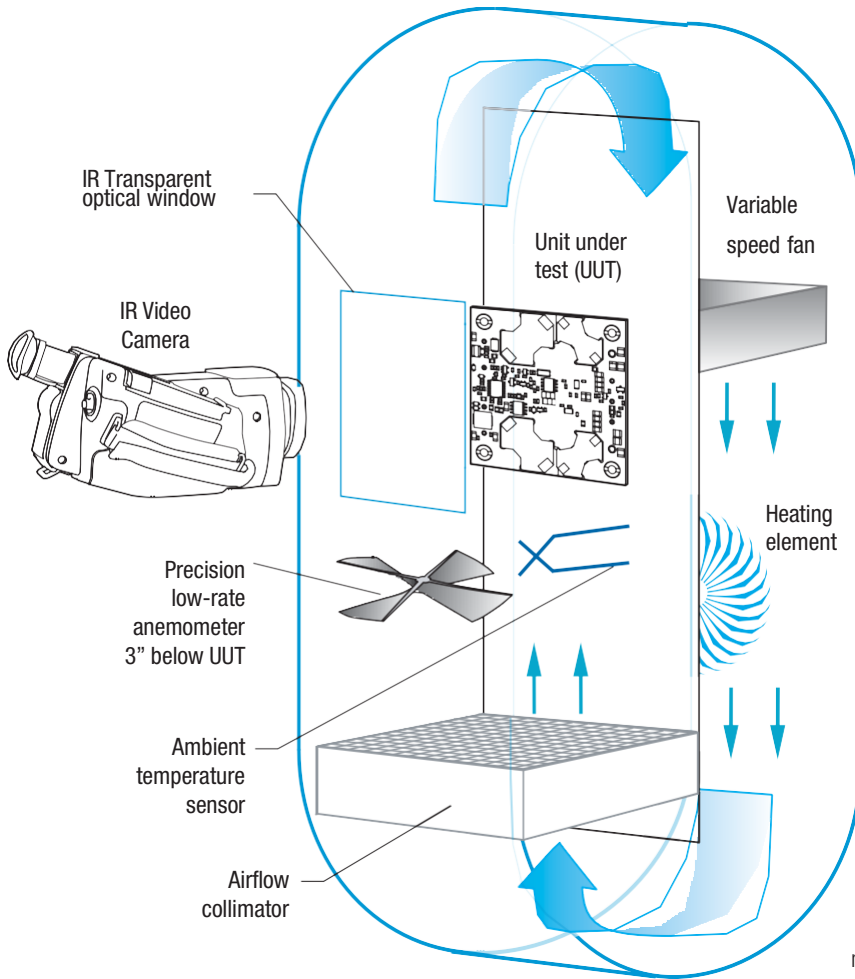

**Vertical Wind Tunnel**

### Vertical Wind Tunnel

Murata Power Solutions employs a computer controlled custom-designed closed loop vertical wind tunnel, infrared video camera system, and test instrumentation for accurate airflow and heat dissipation analysis of power products. The system includes a precision low flow-rate anemometer, variable speed fan, power supply input and load controls, temperature gauges, and adjustable heating element.

The IR camera monitors the thermal performance of the Unit Under Test (UUT) under static steady-state conditions. A special optical port is used which is transparent to infrared wavelengths.

Both through-hole and surface mount converters are soldered down to a 10" x 10" host carrier board for realistic heat absorption and spreading. Both longitudinal and transverse airflow studies are possible by rotation of this carrier board since there are often significant differences in the heat dissipation in the two airflow directions. The combination of adjustable airflow, adjustable ambient heat, and adjustable Input/Output currents and voltages mean that a very wide range of measurement conditions can be studied.

The collimator reduces the amount of turbulence adjacent to the UUT by minimizing airflow turbulence. Such turbulence influences the effective heat transfer characteristics and gives false readings. Excess turbulence removes more heat from some surfaces and less heat from others, possibly causing uneven overheating.

Both sides of the UUT are studied since there are different thermal gradients on each side. The adjustable heating element and fan, built-in temperature gauges, and no-contact IR camera mean that power supplies are tested in real-world conditions.

Murata Power Solutions, Inc.  
129 Flanders Rd., Westborough, MA 01581 USA  
ISO 9001 and 14001 REGISTERED



**This product is subject to the following operating requirements and the Life and Safety Critical Application Sales Policy:**  
Refer to: <https://www.murata-ps.com/requirements/>

Murata Power Solutions, Inc. makes no representation that the use of its products in the circuits described herein, or the use of other technical information contained herein, will not infringe upon existing or future patent rights. The descriptions contained herein do not imply the granting of licenses to make, use, or sell equipment constructed in accordance therewith. Specifications are subject to change without notice.

© 2023 Murata Power Solutions, Inc.