

POMONA Broadcast Connectors



VIDEO BROADCAST

For quantities greater than listed, call for quote.

| MOUSER STOCK NO. | | Fig. | Description | Price Each | | |
|---|---------------|------|---|------------|-------|-------|
| Mfr. | Mfr. Part No. | | | 1 | 25 | 50 |
| 75 Ohm Digital BNC Connectors | | | | | | |
| 565—6705 | | A | BNC (F/F) Isolated Panel Connector for Digital Video | 16.00 | 15.29 | 14.23 |
| 75 Ohm BNC Connectors and Adapters | | | | | | |
| 565—6752A | | B | BNC (m) Crimp for RG59, 59A, 59B, 62, 210 cable | 4.00 | 3.84 | 3.55 |
| 565—6746A | | C | BNC (m) Comp Style, field inst, for RG59, 59A, 59B, 62, 210 cable | 2.65 | 2.55 | 2.36 |
| 75 Ohm BNC Within Series Adapters | | | | | | |
| 565—6738 | | D | BNC (f/f/f) Adapter | 4.10 | 3.92 | 3.64 |
| 565—6739 | | E | BNC (f/m/f) Adapter | 3.93 | 3.72 | 3.53 |
| 565—6754 | | F | BNC (f/m/f) Adapter, In-line | 3.79 | 3.65 | 3.46 |
| 565—6740 | | G | BNC (m/m) Adapter | 2.34 | 2.28 | 2.15 |
| 565—6737 | | H | BNC (f/f) Adapter | 2.60 | 2.53 | 2.40 |
| 565—6744 | | I | BNC (f/f) Panel Mount, Hermetically Sealed Adapter | 3.10 | 3.01 | 2.86 |
| 75 Ohm BNC Panel Receptacles | | | | | | |
| 565—6736 | | J | BNC (f) Panel Receptacle, 0.50 in. (13.46mm) hole spacing | 2.96 | 2.83 | 2.63 |
| 565—6735 | | K | BNC (m) Panel Receptacle, 0.50 in. (13.46mm) hole spacing | 3.50 | 3.35 | 3.12 |
| 75 Ohm BNC Female PCB Mount | | | | | | |
| 565—6748 | | L | BNC (f) PCB Mount, Right Angle | 3.33 | 3.25 | 3.08 |
| 565—6747 | | M | BNC (f) PCB Mount, Vertical | 2.79 | 2.70 | 2.65 |
| 565—6718 | | N | BNC (f) PCB Mount, Dual Right Angle, White Valox | 17.75 | 16.96 | 15.78 |
| 75 Ohm BNC Bulkhead Receptacles | | | | | | |
| 565—6745 | | O | BNC (f) Bulkhead Receptacle, 75 Ohm | 2.40 | 2.33 | 2.21 |
| 565—6741 | | O | BNC (f) Bulkhead Receptacle, Isolated Ground, 75 Ohm | 2.66 | 2.60 | 2.47 |
| 75 Ohm BNC Terminators, Dust Cap, Shorting Cap | | | | | | |
| 565—4391-75 | | P | BNC 75 Ohm Attenuator | 43.50 | 41.76 | 38.69 |
| 565—384075 | | Q | BNC Male Terminator Plug, 75 Ohm | 14.50 | 13.92 | 12.89 |
| 565—4119-75 | | R | BNC Feed-Thru Termination, 75 Ohm | 65.00 | 62.40 | 57.82 |
| 565—5085 | | S | BNC Shorting Cap | 5.03 | 4.71 | 4.44 |
| 565—3839 | | S | BNC Dust Cap | 2.96 | 2.83 | 2.63 |

75 OHM BETWEEN SERIES ADAPTER

For quantities greater than listed, call for quote.

| MOUSER STOCK NO. | | Fig. | Description | Price Each | | |
|------------------|---------------|------|--|------------|-------|-------|
| Mfr. | Mfr. Part No. | | | 1 | 25 | 50 |
| 565—6779 | | T | BNC (m) 75 Ohm / F (f) | 3.47 | 3.37 | 3.20 |
| 565—6780 | | U | BNC (f) 75 Ohm / F (f) | 3.85 | 3.68 | 3.42 |
| 565—6781 | | V | BNC (f) 75 Ohm / F (m) | 3.91 | 3.79 | 3.60 |
| 565—6782 | | W | BNC (m) 75 Ohm / F (m) | 3.91 | 3.79 | 3.60 |
| 565—5319 | | X | BNC Female to Phono Plug | 7.60 | 7.26 | 6.75 |
| 565—4054 | | Y | BNC Male to Phono Jack | 22.19 | 20.01 | 19.06 |
| 565—1297 | | Z | BNC Female to 1/4in (6.35mm) Phone Plug | 11.73 | 11.60 | 11.22 |
| 565—3837 | | AA | BNC Female to Two Conductor, 0.14in (3.5mm) Dia. Tini Plug | 14.27 | 13.69 | 13.23 |
| 565—4043 | | BB | BNC Male to 1/4in (6.35mm) Two Conductor Phone Jack | 44.04 | 42.76 | 40.62 |
| 565—6519 | | CC | BNC Female to Mini-WECO Plug Adapter | 37.23 | 36.14 | 34.32 |
| 565—5008 | | CC | BNC Female to Standard WECO Plug Adapter | 51.01 | 49.53 | 47.04 |
| 565—4719 | | DD | BNC Female to Bantam Plug Adapter | 23.13 | 22.48 | 21.35 |

75 OHM CABLE ASSEMBLIES

For quantities greater than listed, call for quote.

| MOUSER STOCK NO. | | Fig. | Description | Length | Price Each | | |
|------------------|---------------|------|---|--------------|------------|-------|-------|
| Mfr. | Mfr. Part No. | | | | 1 | 25 | 50 |
| 565—6510-V-36-0 | | EE | BNC Male True 75 Ohm High Flex Cable | 36in (0.9m) | 20.00 | 19.20 | 17.79 |
| 565—6510-V-48-0 | | EE | BNC Male True 75 Ohm High Flex Cable | 48in (1.2m) | 23.75 | 22.80 | 21.12 |
| 565—6510-V-60-0 | | EE | BNC Male True 75 Ohm High Flex Cable | 60in (1.5m) | 23.75 | 22.80 | 21.12 |
| 565—6510-V-72-0 | | EE | BNC Male True 75 Ohm High Flex Cable | 72in (1.8m) | 28.50 | 27.36 | 25.35 |
| 565—2249-E-36 | | FF | BNC Male Cable with Molded Strain Reliefs | 3ft (0.9m) | 17.25 | 16.56 | 15.34 |
| 565—2249-E-72 | | FF | BNC Male Cable with Molded Strain Reliefs | 6ft (1.8m) | 20.25 | 19.44 | 18.01 |
| 565—2249-E-120 | | FF | BNC Male Cable with Molded Strain Reliefs | 10ft (3.0m) | 24.50 | 23.52 | 21.79 |
| 565—2249-E-144 | | FF | BNC Male Cable with Molded Strain Reliefs | 12ft (3.7m) | 26.50 | 25.44 | 23.57 |
| 565—2249-E-180 | | FF | BNC Male Cable with Molded Strain Reliefs | 15ft (4.6m) | 29.50 | 28.32 | 26.24 |
| 565—2249-E-240 | | FF | BNC Male Cable with Molded Strain Reliefs | 20ft (6.1m) | 34.50 | 33.12 | 30.69 |
| 565—2249-E-300 | | FF | BNC Male Cable with Molded Strain Reliefs | 25ft (7.6m) | 40.00 | 38.40 | 35.58 |
| 565—2249-E-600 | | FF | BNC Male Cable with Molded Strain Reliefs | 50ft (15.2m) | 66.00 | 63.36 | 58.71 |

F CONNECTORS

For quantities greater than listed, call for quote.

| MOUSER STOCK NO. | | Fig. | Description | Price Each | | |
|---|---------------|------|--|------------|------|------|
| Mfr. | Mfr. Part No. | | | 1 | 25 | 50 |
| 75 Ohm Type "F" Within Series Adapters | | | | | | |
| 565—6800 | | GG | 75Ω Type F (m/f) Right Angle Adapter | 3.71 | 3.54 | 3.30 |
| 565—6801 | | HH | 75Ω Type F (m/f) in-line Adapter | 1.50 | 1.36 | 1.32 |
| 75 Ohm Type "F" Bulkhead Receptacle | | | | | | |
| 565—6802 | | II | 75Ω Type F (f/f) in-line, with nut and washer | 1.55 | 1.48 | 1.38 |
| 75 Ohm Type "F" PCB Mount | | | | | | |
| 565—6803 | | JJ | 75Ω Type F(f), vertical mount with PTFE insulator. | 2.18 | 2.12 | 2.01 |

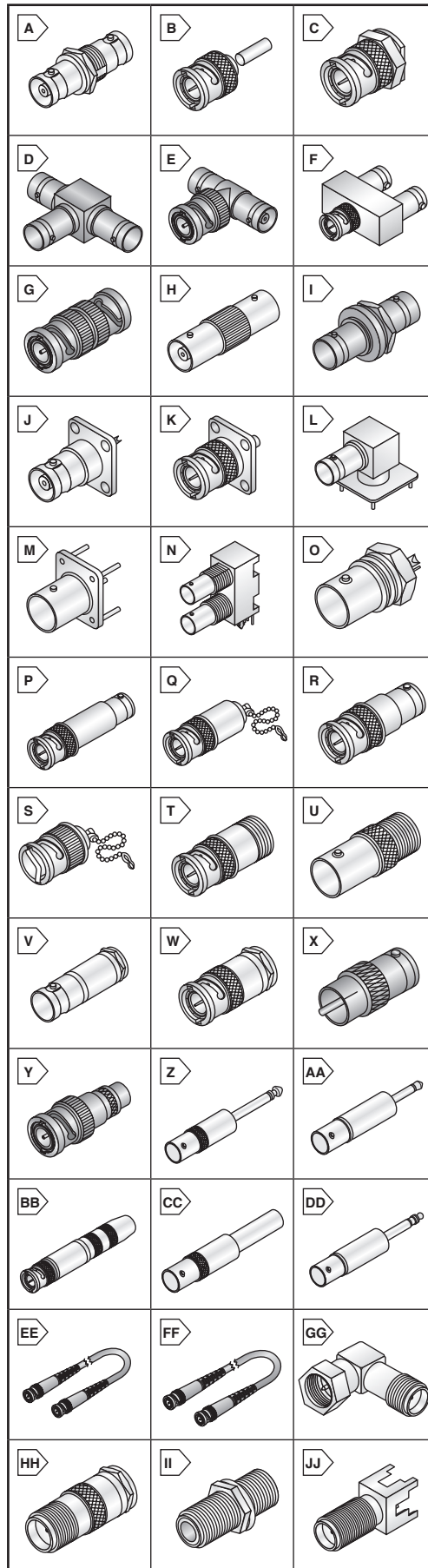

Pomona Audio/Video Connectors