

LAIRD TECHNOLOGIES Ferrite Cable EMI Filters



RoHS Compliant This product is RoHS compliant.

SNAP-ON EMI FERRITE CLAMP FILTERS IN PLASTIC CASES

- Features:**
- For retrofit and post assembly usages
 - Excellent common and differential mode EMI suppression
 - Black or white plastic snap-on cases provide secure closure
 - For round cables and wire bundles

For quantities greater than listed, call for quote.

MOUSER STOCK NO.	Steward Part No.	Fig.	Impedance @ 100MHz (Ω)	Maximum Cable Diameter	Dimensions: mm			Case Color	Price Each			
					A	B	C		1	10	50	100
875-28A0350-0B2	28A0350-0B2	A	240	3.50	13.00	3.50	25.20	Black	1.43	1.18	1.02	.924
875-28A0392-0A0	28A0392-0A0	A	170	4.75	13.72	5.44	30.56	White	.98	.818	.713	.64
875-28A0392-0A2	28A0392-0A2	A	170	4.75	13.72	5.44	30.56	Black	.98	.818	.713	.64
875-28A2026-0A2	28A2026-0A2	A	270	6.35	21.00	6.80	41.70	Black	1.93	1.60	1.38	1.24
875-28A2736-0A0	28A2736-0A0	A	220	8.90	19.70	9.00	35.10	Black	1.21	1.00	.871	.787
875-28A0640-0A2	28A0640-0A2	A	240	8.95	19.90	9.80	41.40	Black	1.36	1.12	.976	.881
875-28A3851-0A2	28A3851-0A2	A	260	12.85	30.00	13.00	33.70	Black	10.53	9.27	7.64	6.59
875-28A2005-0A2	28A2005-0A2	B	190	2.50	13.00	5.00	23.50	Black	.61	.474	.426	.388
875-28A2307-0A2	28A2307-0A2	B	183	7.00	16.50	7.00	30.50	Black	.89	.695	.627	.57
875-28A2738-0A0	28A2738-0A0	B	233	8.00	19.70	9.00	35.10	White	1.10	.853	.775	.705
875-28A2738-0A2	28A2738-0A2	B	233	8.00	19.70	9.00	35.10	Black	.79	.61	.554	.504
875-28A2432-0A2	28A2432-0A2	B	160	8.05	19.20	8.20	19.90	Black	1.95	1.61	1.39	1.24
875-28A2809-0A2	28A2809-0A2	B	220	9.00	16.00	9.00	28.00	Black	1.85	1.43	1.29	1.18
875-28A3039-0A2	28A3039-0A2	B	130	10.15	24.55	10.20	13.60	Black	2.05	1.70	1.46	1.32
875-28A2913-0A2	28A2913-0A2	B	177	13.00	23.50	13.06	36.25	Black	1.25	.972	.884	.803
875-28A4155-0A2	28A4155-0A2	B	120	13.55	28.80	13.60	15.40	Black	3.20	2.64	2.29	2.04
875-28A1507-0A2	28A1507-0A2	B	123	22.00	15.00	7.00	18.00	Black	.61	.47	.42	.38
875-28A2025-0A0	28A2025-0A0	C	320	6.35	18.15	7.05	32.50	White	1.34	1.10	.965	.86
875-28A2025-0A2	28A2025-0A2	C	320	6.45	18.15	7.05	32.50	Black	1.34	1.10	.955	.86
875-28A2029-0A0	28A2029-0A0	C	250	9.95	22.28	10.00	32.77	White	1.75	1.44	1.24	1.12
875-28A2029-0A2	28A2029-0A2	C	250	9.95	22.28	10.00	32.77	Black	1.75	1.44	1.24	1.12
875-28A2024-0A0	28A2024-0A0	C	280	12.85	29.00	13.00	32.50	White	3.07	2.54	2.18	1.96
875-28A0592-0A2	28A0592-0A2	D	572	4.40	18.75	5.04	53.39	Black	1.84	1.52	1.31	1.17
875-28A0434-0A2	28A0434-0A2	D	227	5.05	14.71	5.44	42.88	Black	1.22	1.01	.882	.787
875-28A0593-0A2	28A0593-0A2	D	407	6.50	18.75	6.75	52.91	Black	1.88	1.53	1.32	1.07
875-28A5131-0A2	28A5131-0A2	E	425	25.40	56.64	19.50	45.00	Black	11.84	9.80	8.44	7.60

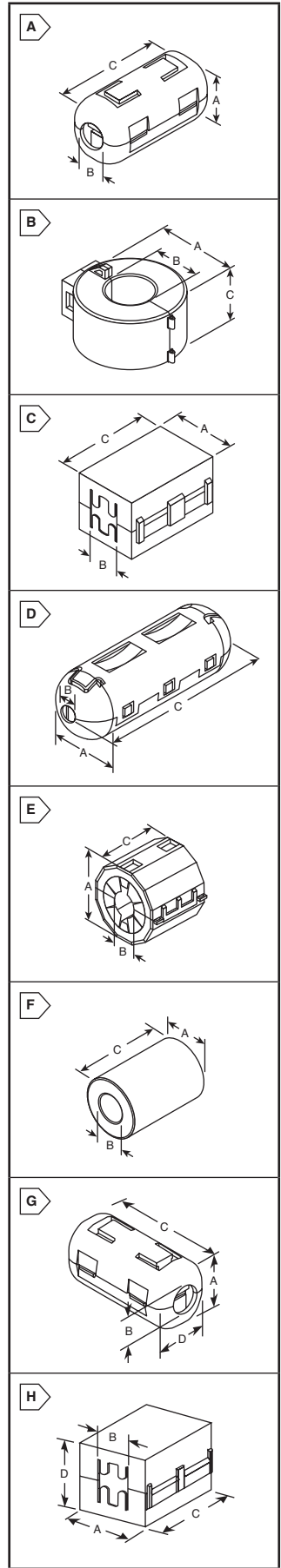

EMI Suppression Laird Technologies

ROUND AND CYLINDRICAL FERRITE EMI SUPPRESSION CORES

- Features:**
- Excellent common and differential mode EMI suppression
 - For round cables and wire bundles
 - Broadband performance
 - Impedance value is NET impedance of the ferrite core only

For quantities greater than listed, call for quote.

MOUSER STOCK NO.	Steward Part No.	Fig.	Impedance @ 100MHz (Ω)	Dimensions: mm			Price Each			
				A	B	C	1	10	50	100
875-28B0268-000	28B0268-000	F	138	6.78	3.99	14.22	.14	.11	.10	.09
875-28B0375-100	28B0375-100	F	154	9.53	5.08	14.48	.19	.168	.147	.126
875-28B0375-300	28B0375-300	F	194	9.53	5.08	19.05	.23	.188	.167	.146
875-28B0485-000	28B0485-000	F	320	12.32	4.88	25.40	.61	.512	.441	.398
875-28B0500-100	28B0500-100	F	83	12.70	7.92	6.35	.16	.136	.125	.104
875-28B0562-200	28B0562-200	F	317	14.27	6.35	28.58	.60	.504	.441	.399
875-28B0563-200	28B0563-200	F	287	14.27	7.26	28.57	.57	.482	.409	.367
875-28B0625-100	28B0625-100	F	280	15.88	7.87	28.58	.69	.577	.503	.451
875-28B0631-100	28B0631-100	F	243	16.00	9.25	28.00	.63	.525	.451	.409
875-28B0672-000	28B0672-000	F	245	17.07	8.76	25.40	1.07	.829	.755	.682
875-28B0686-000	28B0686-000	F	91	17.42	9.52	6.35	.24	.21	.178	.157
875-28B0686-100	28B0686-100	F	139	17.42	9.52	12.70	1.15	.897	.811	.74
875-28B0686-200	28B0686-200	F	242	17.42	9.52	28.58	.76	.64	.545	.493
875-28B0734-000	28B0734-000	F	229	18.67	11.18	28.58	1.97	1.53	1.39	1.26
875-28B0735-000	28B0735-000	F	250	18.67	10.16	28.58	.87	.724	.629	.566
875-28B0870-100	28B0870-100	F	122	22.10	13.72	12.70	.51	.43	.367	.335
875-28B1000-000	28B1000-000	F	151	25.40	12.70	12.70	1.04	.871	.755	.682
875-28B1020-100	28B1020-100	F	276	25.91	12.83	28.58	1.70	1.40	1.20	1.09
875-28B1122-100	28B1122-100	F	307	28.50	13.77	28.58	2.05	1.70	1.45	1.31
875-28B1142-000	28B1142-000	F	85	29.01	19.00	7.49	.70	.581	.506	.447

LAIRD HIGH FREQUENCY (300MHZ - 2GHZ) SPLIT/SNAP-ON FERRITE CORES FOR CABLES AND WIRING HARNESSSES

For quantities greater than listed, call for quote.

MOUSER STOCK NO.	Steward Part No.	Fig.	Net Impedance @ 500 MHz (Ω)	Net Impedance @ 800 MHz (Ω)	Max. Cable Dia. (mm)	Dimensions: mm				Case Color	Price Each			
						A	B	C	D		1	10	50	100
875-HFA100049-0A2	HFA100049-0A2	G	152	168	4.88	12.80	5.30	29.30	12.40	Black	2.10	1.73	1.50	1.20
875-HFA150068-0A2	HFA150068-0A2	G	340	281	6.76	21.03	8.13	41.68	21.00	Black	2.77	2.30	1.98	1.72
875-HFA163090-0A2	HFA163090-0A2	G	260	262	9.01	19.10	9.09	40.36	20.80	Black	4.03	3.33	2.86	2.29
875-HFA150066-0A2	HFA150066-0A2	H	350	339	6.60	17.88	7.00	32.50	18.90	Black	3.36	2.79	2.41	2.16
875-HFA187102-0A2	HFA187102-0A2	H	290	280	10.16	21.77	10.00	32.64	21.95	Black	4.45	3.71	3.19	2.88
875-HFA259131-0A2	HFA259131-0A2	H	315	275	13.06	29.01	13.00	32.51	29.60	Black	5.25	4.35	3.76	3.38