

AMP CPC Accessories

RoHS Compliant This product is RoHS compliant.

SHELL SIZE 11 ACCESSORIES

• RoHS compliant per Tyco Electronics documentation



E28476 LR7189

For quantities of 100 and up, call for quote.

MOUSER STOCK NO.	AMP Part No.	Fig.	Description	Price Each		
				1	25	50
571-1-206062-6	1-206062-6	A	Std cable clamp, screw length .375"			
571-1-206062-4	1-206062-4	A	Std cable clamp, screw length .500"			
571-206358-5	206358-5	B	Large cable clamp			
571-1546347-2	1546347-2	C	Right-angle cable clamp w/ cover			
571-207489-1	207489-1	D	Flexible cable boot			
571-207490-1	207490-1	E	Internal cable grip			
571-54010-1	54010-1	F	Heat shrink sealing boot			
571-2064031	206403-1	G	Peripheral seal			
571-208800-1	208800-1	I	Sealing cap metal chain			
571-2063041	206304-1	J	Rubber boot			
571-2138111	213811-1	K	Replacement coupling ring			
571-207299-1	207299-1	L	Panel mount flange for plug			

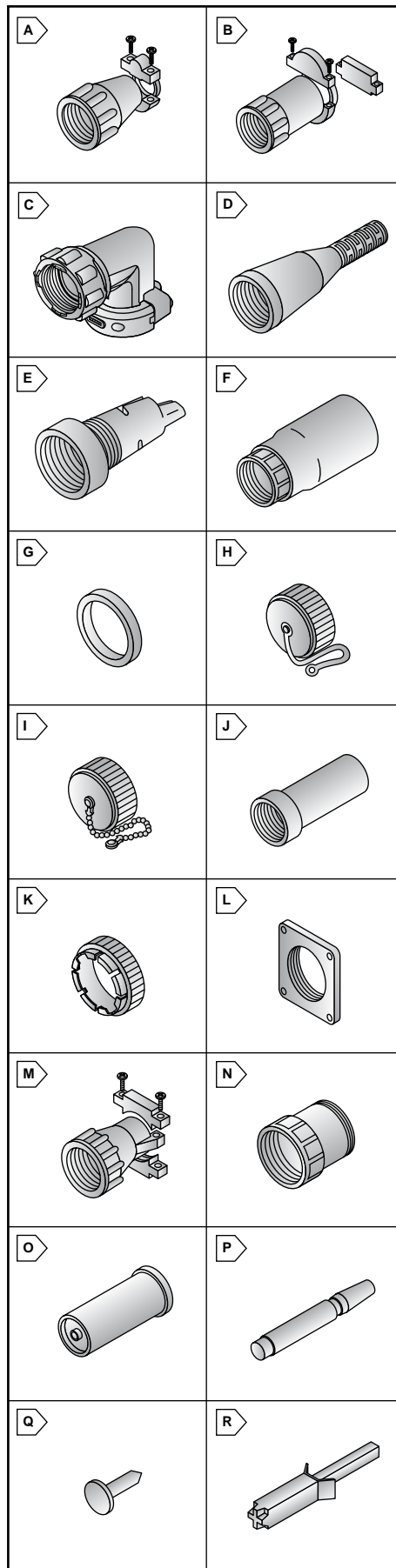

Circular Connectors AMP

SHELL SIZE 13 ACCESSORIES

• RoHS compliant per Tyco Electronics documentation



E28476 LR7189

For quantities of 100 and up, call for quote.

MOUSER STOCK NO.	AMP Part No.	Fig.	Description	Price Each		
				1	25	50
571-206966-7	206966-7	A	Standard cable clamp			
571-207008-5	207008-5	B	Large cable clamp			
571-1546348-2	1546348-2	C	Right-angle cable clamp w/ cover			
571-54123-1	54123-1	F	Heat shrink sealing boot			
571-2064034	206403-4	G	Peripheral seal			
571-211870-1	211870-1	H	Sealing cap plastic strap			
571-2134851	213485-1	I	Sealing cap metal chain			
571-2138131	213813-1	K	Replacement coupling ring			
571-207299-2	207299-2	L	Panel mount flange for plug			

SHELL SIZE 17 ACCESSORIES

• RoHS compliant per Tyco Electronics documentation



E28476 LR7189

For quantities of 100 and up, call for quote.

MOUSER STOCK NO.	AMP Part No.	Fig.	Description	Price Each		
				1	25	50
571-206070-8	206070-8	A	Standard cable clamp			
571-206322-9	206322-9	B	Large cable clamp			
571-1546349-2	1546349-2	C	Right-angle cable clamp w/ cover			
571-2072411	207241-1	D	Flexible cable boot			
571-2073871	207387-1	E	Small internal cable grip			
571-2073872	207387-2	E	Large internal cable grip			
571-54011-1	54011-1	F	Heat shrink sealing boot			
571-2064032	206403-2	G	Peripheral seal			
571-207445-1	207445-1	H	Sealing cap plastic strap			
571-2086521	208652-1	I	Sealing cap metal chain			
571-2138101	213810-1	K	Replacement coupling ring			
571-2072993	207299-3	L	Panel mount flange for plug			

SHELL SIZE 23 ACCESSORIES

• RoHS compliant per Tyco Electronics documentation



E28476 LR7189

For quantities of 100 and up, call for quote.

MOUSER STOCK NO.	AMP Part No.	Fig.	Description	Price Each		
				1	25	50
571-206138-8	206138-8	A	Standard cable clamp			
571-206512-5	206512-5	B	Large cable clamp			
571-1546350-2	1546350-2	C	Right-angle cable clamp w/ cover			
571-207774-3	207774-3	M	Self-centering cable clamp			
571-54012-1	54012-1	F	Heat shrink sealing boot			
571-2064033	206403-3	G	Peripheral seal			
571-2072994	207299-4	L	Panel mount flange for plug			
571-2070551	207055-1	N	Back-shell extender			
571-2074461	207446-1	H	Sealing cap plastic strap series 1,3,4			
571-2074462	207446-2	H	Sealing cap plastic strap, Series 2			
571-2070521	207052-1	O	Jacketed cable seal .30" - .45"			
571-2070522	207052-2	O	Jacketed cable seal .45" - .60"			
571-2070523	207052-3	O	Jacketed cable seal .60" - .875"			
571-2086801	208680-1	I	Sealing cap metal chain			
571-2138121	213812-1	K	Replacement coupling ring			

KEYING PLUGS

• RoHS compliant per Tyco Electronics documentation



E28476 LR7189

For quantities of 100 and up, call for quote.

MOUSER STOCK NO.	AMP Part No.	Fig.	Description	Price Each		
				1	25	50
571-2008211	200821-1	P	Series 1 and 4 keying plug			
571-2065091	206509-1	Q	Series 2 keying plug			
571-2065081	206508-1	R	Series 3 and 4 keying plug sockets			
571-2075971	207597-1	R	Series 3 and 4 keying plug pins			